



E-800A
INSTALLATION AND SERVICE GUIDE

A guide for service technicians

Copyright © 2000 Electronics For Imaging. All rights reserved.

This publication is protected by copyright, and all rights are reserved. No part of it may be reproduced or transmitted in any form or by any means for any purpose without express prior written consent from Electronics For Imaging, except as expressly permitted herein. Information in this document is subject to change without notice and does not represent a commitment on the part of Electronics For Imaging.

The software described in this publication is furnished under license and may only be used or copied in accordance with the terms of such license.

Patents: 5,867,179; 5,835,788; 5,666,436; 5,553,200; 5,543,940; 5,537,516; 5,517,334; 5,506,946; 5,424,754; 5,343,311; 5,212,546; 4,941,038; 4,837,722; 4,500,919; D406,117

Trademarks

EFI, the EFI logo, Fiery, the Fiery logo, Fiery Driven, the Fiery Driven logo, EFICOLOR, ColorWise, and Rip-While-Print are trademarks registered in the U.S. Patent and Trademark Office. Fiery ZX, Fiery X2, Command WorkStation, AutoCal, Starr Compression, Memory Multiplier, NetWise, and VisualCal are trademarks of Electronics For Imaging, Inc.

Adobe, the Adobe logo, Adobe Illustrator, PostScript, Adobe Photoshop, Adobe Separator, and Adobe PageMaker are trademarks of Adobe Systems Incorporated, registered in certain jurisdictions. EPS (Encapsulated PostScript) is a trademark of Altsys Corporation. Apple, the Apple logo, AppleShare, AppleTalk, EtherTalk, LaserWriter, and Macintosh are registered trademarks, and MultiFinder is a trademark of Apple Computer, Inc. Microsoft, MS, MS-DOS, and Windows are registered trademarks of Microsoft in the US and other countries. QuarkXPress is a registered trademark of Quark, Inc. Times, Helvetica, and Palatino are trademarks of Linotype AG and/or its subsidiaries. ITC Avant Garde, ITC Bookman, ITC Zapf Chancery, and ITC Zapf Dingbats are registered trademarks of International Typeface Corporation. Ethernet is a registered trademark of Xerox Corporation. NetWare and Novell are registered trademarks and Internetwork Packet Exchange (IPX) is a trademark of Novell, Inc. UNIX is a registered trademark of UNIX System Laboratories, a wholly owned subsidiary of Novell, Inc. PANTONE is a registered trademark of Pantone, Inc.

All other terms and product names may be trademarks or registered trademarks of their respective owners, and are hereby acknowledged.

Legal Notices

APPLE COMPUTER, INC. ("APPLE") MAKES NO WARRANTIES, EXPRESS OR IMPLIED, INCLUDING WITHOUT LIMITATION THE IMPLIED WARRANTIES OF MERCHANTABILITY AND FITNESS FOR A PARTICULAR PURPOSE, REGARDING THE APPLE SOFTWARE. APPLE DOES NOT WARRANT, GUARANTEE, OR MAKE ANY REPRESENTATIONS REGARDING THE USE OR THE RESULTS OF THE USE OF THE APPLE SOFTWARE IN TERMS OF ITS CORRECTNESS, ACCURACY, RELIABILITY, CURRENTNESS, OR OTHERWISE. THE ENTIRE RISK AS TO THE RESULTS AND PERFORMANCE OF THE APPLE SOFTWARE IS ASSUMED BY YOU. THE EXCLUSION OF IMPLIED WARRANTIES IS NOT PERMITTED BY SOME STATES. THE ABOVE EXCLUSION MAY NOT APPLY TO YOU.

IN NO EVENT WILL APPLE, ITS DIRECTORS, OFFICERS, EMPLOYEES OR AGENTS BE LIABLE TO YOU FOR ANY CONSEQUENTIAL, INCIDENTAL OR INDIRECT DAMAGES (INCLUDING DAMAGES FOR LOSS OF BUSINESS PROFITS, BUSINESS INTERRUPTION, LOSS OF BUSINESS INFORMATION, AND THE LIKE) ARISING OUT OF THE USE OR INABILITY TO USE THE APPLE SOFTWARE EVEN IF APPLE HAS BEEN ADVISED OF THE POSSIBILITY OF SUCH DAMAGES. BECAUSE SOME STATES DO NOT ALLOW THE EXCLUSION OR LIMITATION OF LIABILITY FOR CONSEQUENTIAL OR INCIDENTAL DAMAGES, THE ABOVE LIMITATIONS MAY NOT APPLY TO YOU. Apple's liability to you for actual damages from any cause whatsoever, and regardless of the form of the action (whether in contract, tort [including negligence], product liability or otherwise), will be limited to \$50.

Restricted Rights Legends

For defense agencies: Restricted Rights Legend. Use, reproduction, or disclosure is subject to restrictions set forth in subparagraph (c)(1)(ii) of the Rights in Technical Data and Computer Software clause at 252.227.7013.

For civilian agencies: Restricted Rights Legend. Use, reproduction, or disclosure is subject to restrictions set forth in subparagraph (a) through (d) of the commercial Computer Software Restricted Rights clause at 52.227-19 and the limitations set forth in Electronics For Imaging's standard commercial agreement for this software. Unpublished rights reserved under the copyright laws of the United States.

Printed in the United States of America on recycled paper.

CE Mark

The CE marking applied to this product symbolises Ricoh's declaration of conformity with the following applicable directives of the European Union as of the dates indicated.

January 1, 1996—Council Directive 73/23/EEC amended by Council Directive 98/68/EEC. Approximation of the laws of the member states related to low voltage equipment.

January 1, 1996—Council Directive 89/336/EEC. Approximation of the laws of the member states related to electromagnetic compatibility.

CE Marking (Declaration of Conformity)

We declare under our sole responsibility that the copier and options to which this declaration relates is in conformity with the specification below. This declaration is valid for the area of the European Union (EU) only.

WARNING: In order to allow this equipment to operate in proximity to industrial, scientific, and Medical (ISM) equipment, the external radiation from ISM equipment may have to be limited or special migration measures taken.

FCC Class B Compliance

NOTE: This equipment has been tested and found to comply with the limits for a Class B digital device, pursuant to Part 15 of the FCC Rules. These limits are designed to provide reasonable protection against harmful interference when the equipment is operated in a commercial environment. This equipment generates, and uses, and can radiate radio frequency energy and, if not installed and used in accordance with the instruction manual, may cause harmful interference to radio communications. Operation of this equipment in a residential area is likely to cause harmful interference in which case the user will be required to correct the interference at his own expense.

WARNING: The design and production of this unit conform to FCC regulations, and any changes or modifications must be registered with the FCC and are subject to FCC control. Any changes made by the purchaser or user without first contacting the manufacturer will be subject to penalty under FCC regulations.

Industry Canada Class B Notice

This Class B digital apparatus complies with Canadian ICES-003.

Avis de Conformation Classe B de l'Industrie Canada

Cet appareil numérique de la classe B est conforme à la norme NMB-003 du Canada.

Software License Agreement

Before using the Software, please carefully read the following terms and conditions. BY USING THIS SOFTWARE, YOU SIGNIFY THAT YOU HAVE ACCEPTED THE TERMS OF THIS AGREEMENT. If you cannot or do not accept these terms, you may return the entire package within ten (10) days to the Distributor or Dealer from which you obtained them for a full refund.

Electronics For Imaging grants to you a non-exclusive, non-transferable license to use the software and accompanying documentation ("Software") included with the E-800A you have purchased, including without limitation the PostScript software provided by Adobe Systems Incorporated.

You may:

- a. use the Software solely for your own customary business purposes and solely with E-800A;
- b. use the digitally-encoded machine-readable outline and bitmap programs ("Font Programs") provided with E-800A in a special encrypted format ("Coded Font Programs") to reproduce and display designs, styles, weights, and versions of letters, numerals, characters and symbols ("Typefaces") solely for your own customary business purposes on the display window of the E-800A or monitor used with E-800A;
- c. use the trademarks used by Electronics For Imaging to identify the Coded Font Programs and Typefaces reproduced therefrom ("Trademarks"); and
- d. assign your rights under this Agreement to a transferee of all of your right, title and interest in and to E-800A provided the transferee agrees to be bound by all of the terms and conditions of this Agreement.

You may not:

- a. make use of the Software, directly or indirectly, to print bitmap images with print resolutions of 600 dots per inch or greater, or to generate fonts or typefaces for use other than with E-800A;
- b. make or have made, or permit to be made, any copies of the Software, Coded Font Programs, accompanying documentation or portions thereof, except as necessary for use with the E-800A unit purchased by you; provided, however, that under no circumstances may you make or have made, or permit to be made, any copies of that certain portion of the Software which has been included on the E-800A hard disk drive. You may not copy the documentation;
- c. attempt to alter, disassemble, decrypt or reverse engineer the Software, Coded Font Programs or accompanying documentation.
- d. rent or lease the Software.

Proprietary Rights

You acknowledge that the Software, Coded Font Programs, Typefaces, Trademarks and accompanying documentation are proprietary to Electronics For Imaging and its suppliers and that title and other intellectual property rights therein remain with Electronics For Imaging and its suppliers. Except as stated above, this Agreement does not grant you any right to patents, copyrights, trade secrets, trademarks (whether registered or unregistered), or any other rights, franchises or licenses in respect of the Software, Coded Font Programs, Typefaces, Trademarks or accompanying documentation. You may not adapt or use any trademark or trade name which is likely to be similar to or confusing with that of Electronics For Imaging or any of its suppliers or take any other action which impairs or reduces the trademark rights of Electronics For Imaging or its suppliers. The trademarks may only be used to identify printed output produced by the Coded Font Programs. At the reasonable request of Electronics For Imaging, you must supply samples of any Typeface identified with a trademark.

Confidentiality

You agree to hold the Software and Coded Font Programs in confidence, disclosing the Software and Coded Font Programs only to authorized users having a need to use the Software and Coded Font Programs as permitted by this Agreement and to take all reasonable precautions to prevent disclosure to other parties.

Remedies

Unauthorized use, copying or disclosure of the Software, Coded Font Programs, Typefaces, Trademarks or accompanying documentation will result in automatic termination of this license and will make available to Electronics For Imaging other legal remedies.

Limited Warranty And Disclaimer

Electronics For Imaging warrants that, for a period of ninety (90) days from the date of delivery to you, the Software under normal use will perform without significant errors that make it unusable. Electronics For Imaging's entire liability and your exclusive remedy under this warranty (which is subject to you returning E-800A to Electronics For Imaging or an authorized dealer) will be, at Electronics For Imaging's option, to use reasonable commercial efforts to attempt to correct or work around errors, to replace the Software with functionally equivalent software, or to refund the purchase price and terminate this Agreement. Some states do not allow limitations on duration of implied warranty, so the above limitation may not apply to you.

Except for the above express limited warranty, Electronics For Imaging makes and you receive no warranties or conditions on the Products, express, implied, or statutory, and Electronics For Imaging specifically disclaims any implied warranty or condition of merchantability or fitness for a particular purpose.

For warranty service, please contact your authorized service/support center.

EXCEPT FOR THE ABOVE EXPRESS LIMITED WARRANTY, ELECTRONICS FOR IMAGING MAKES AND YOU RECEIVE NO WARRANTIES OR CONDITIONS ON THE SOFTWARE OR CODED FONT PROGRAMS, EXPRESS, IMPLIED, STATUTORY, OR IN ANY OTHER PROVISION OF THIS AGREEMENT OR COMMUNICATION WITH YOU, AND ELECTRONICS FOR IMAGING SPECIFICALLY DISCLAIMS ANY IMPLIED WARRANTY OR CONDITION OF MERCHANTABILITY OR FITNESS FOR A PARTICULAR PURPOSE. Electronics For Imaging does not warrant that the operation of the software will be uninterrupted or error free or that the Software will meet your specific requirements.

Limitation Of Liability

IN NO EVENT WILL ELECTRONICS FOR IMAGING OR ITS SUPPLIERS BE LIABLE FOR ANY DAMAGES, INCLUDING LOSS OF DATA, LOST PROFITS, COST OF COVER OR OTHER SPECIAL, INCIDENTAL, CONSEQUENTIAL OR INDIRECT DAMAGES ARISING FROM THE USE OF THE SOFTWARE, CODED FONT PROGRAMS OR ACCOMPANYING DOCUMENTATION, HOWEVER CAUSED AND ON ANY THEORY OF LIABILITY. THIS LIMITATION WILL APPLY EVEN IF ELECTRONICS FOR IMAGING OR ANY AUTHORIZED DEALER HAS BEEN ADVISED OF THE POSSIBILITY OF SUCH DAMAGE. YOU ACKNOWLEDGE THAT THE PRICE OF THE UNIT REFLECTS THIS ALLOCATION OF RISK. BECAUSE SOME STATES/JURISDICTIONS DO NOT ALLOW THE EXCLUSION OR LIMITATION OF LIABILITY FOR CONSEQUENTIAL OR INCIDENTAL DAMAGES, THE ABOVE LIMITATION MAY NOT APPLY TO YOU.

Export Controls

You agree that you will not export or re-export the Software or Coded Font Programs in any form without the appropriate United States and foreign government licenses. Your failure to comply with this provision is a material breach of this Agreement.

Government Use

Use, duplication or disclosure of the Software by the United States Government is subject to restrictions as set forth in subdivision (c) (1) (ii) of the Rights in Technical Data and Computer Software clause at DFARS 252.227-7013 or in subparagraphs (c) (1) and (2) of the Commercial Computer Software—Restricted Right Clause at 48 CFR 52.227-19, as applicable.

Third Party Beneficiary

You are hereby notified that Adobe Systems Incorporated, a California corporation located at 345 Park Avenue, San Jose, CA 95110-2704 ("Adobe") is a third-party beneficiary to this Agreement to the extent that this Agreement contains provisions which relate to your use of the Fonts, the Coded Font Programs, the Typefaces and the Trademarks licensed hereby. Such provisions are made expressly for the benefit of Adobe and are enforceable by Adobe in addition to Electronics For Imaging.

General

This Agreement will be governed by the laws of the State of California.

This Agreement is the entire agreement held between us and supersedes any other communications or advertising with respect to the Software, Coded Font Programs and accompanying documentation.

If any provision of this Agreement is held invalid, the remainder of this Agreement shall continue in full force and effect.

If you have any questions concerning this Agreement, please write to Electronics For Imaging, Attn: Licensing Dept. or see Electronics For Imaging's web site at www.efi.com.

Electronics For Imaging
303 Velocity Way
Foster City, CA 94404

Contents

Preface

About this guide	xi
About the illustrations in this guide	xi
Terminology and conventions	xii
Precautions	xiii
Tools you will need	xv

Chapter 1: Introduction

Features	1-1
How the E-800A operates	1-2
Print options	1-3
User software	1-4
Fiery WebTools	1-5

Chapter 2: Preparing for Installation

Installation sequence	2-1
Checking the customer site	2-3
Setting customer expectations	2-4
Unpacking the E-800A	2-5
E-800A panels	2-7

Chapter 3: Connecting the E-800A

Preliminary checkout	3-1
Connecting to the copier	3-4
Verifying the connection	3-6
Printing the E-800A Test Page and Configuration page	3-6
Installing additional options	3-9
Connecting to the network	3-9
Using the Control Panel	3-11
Activity light	3-12
Buttons	3-12
Control Panel screens and icons	3-13
Shutting down and restarting the E-800A	3-18

Contents

Chapter 4: Service Procedures

Overview	4-1
System software service	4-1
Accessing E-800A internal components	4-3
Accessing front panel components	4-6
Checking E-800A internal connections	4-8
Restoring E-800A functionality after service	4-11
Removing and replacing boards	4-13
IX UIB board	4-14
AGP video board	4-16
Copier interface board	4-18
User interface board	4-20
Motherboard	4-23
Removing the E-800A motherboard	4-23
Replacing the motherboard	4-28
Replacing parts on the motherboard	4-30
Motherboard jumpers and switches	4-36
Fans	4-36
Front fan	4-36
Back panel fan	4-38
Power supply	4-40
Checking voltages	4-40
Removing and replacing the power supply	4-42
Hard disk drive	4-43
ZIP drive	4-47
CD-ROM drive	4-50
Front panel components	4-53
Jewels	4-54
Buttons	4-54
E-800A system software service	4-55
Retrieving backup system software	4-56
Installing system software from a CD	4-57

Contents

Chapter 5: Troubleshooting

The troubleshooting process	5-1
Where problems occur	5-2
Before you go to the customer site	5-3
Preliminary on-site checkout	5-5
Checking interface cables	5-5
Checking internal components	5-6
Checking the E-800A as a stand-alone unit	5-8
Errors and beep codes during startup diagnostics	5-9
General E-800A system error conditions	5-12
Copier interface board diagnostics	5-17
Checking the entire E-800A system	5-18
Checking the copier interface	5-18
Checking network connections	5-20
Printing to the E-800A	5-21

Appendix A: Specifications

Hardware features	A-1
Networking and connectivity	A-1
User software	A-1
Safety and emissions compliance	A-1
Output voltage	A-2

Appendix B: Interface Unit and Extender Board Installation Procedures

Index

About this guide

Preface

The *Installation and Service Guide* is intended for certified E-800A™ and copier service technicians installing or servicing the E-800A Color Server. If you have not received installation and service certification, you should not attempt to install or service the E-800A Color Server. Electronics For Imaging does not warrant the performance if installed or serviced by non-certified personnel.

About this guide

This guide is divided into the following topics:

- “Preface”
General information about this guide and about installing the E-800A
- Chapter 1, “Introduction”
General information about the E-800A
- Chapter 2, “Preparing for Installation”
Unpacking and the steps you need to take before you install the unit
- Chapter 3, “Connecting the E-800A”
How to connect the E-800A to the copier and the network and verify that the system is working correctly; overview of the Control Panel
- Chapter 4, “Service Procedures”
Removal and replacement procedures for E-800A components
- Chapter 5, “Troubleshooting”
Common problems and ways of correcting them; startup error codes

NOTE: E-800A customers should not use the technical service documentation. Please don't leave your copy of the *Installation and Service Guide* after you make a service call.

About the illustrations in this guide

The illustrations in this guide reflect the current shipping version of the E-800A at the time of publication. Components shown in these illustrations are subject to change. To receive information about any E-800A components that do not match the illustrations in this guide, contact your authorized service/support center.

Terminology and conventions

The term “network administrator” refers to the person responsible for maintaining the network at the customer site.

The term “Control Panel” refers to the area on the front of the E-800A including the green/red activity light, the display window (LCD—liquid crystal display), and the buttons to the right of and below the display window.

The term “system software” refers to the software installed on the E-800A hard disk drive.

Client utilities can be installed onto the E-800A from the User Software CD if the Fiery Advanced Controller Interface option is installed. Do not install any other applications onto the E-800A. Other applications are not supported and can cause system problems.

References to other E-800A manuals, such as the *Configuration Guide*, are displayed in italics.

NOTE: The note format highlights important messages and additional information.



The caution icon indicates a need for special care and safety when handling the equipment.

Precautions

Precautions

Always observe the following general precautions when installing and servicing the E-800A:

1. Report any shipping damage.

If there is any evidence of shipping or handling damage to the E-800A packing boxes or their contents, save the damaged boxes and parts, call the shipper immediately to file a claim, and notify your authorized service/support center.

2. Never alter an existing network without permission.

The E-800A will probably be connected to an existing Local Area Network (LAN) based on Ethernet hardware. The network is the link between the customer's computer, existing laser printers, and other prepress equipment. Never disturb the LAN by breaking or making a network connection, altering termination, installing or removing networking hardware or software, or shutting down networked devices without the knowledge and express permission of the system or network administrator or the shop supervisor.

3. Never assign an IP address in the E-800A Network Setup.

Only the network administrator should assign an IP address to a network device. Assigning the E-800A an incorrect IP address may cause unpredictable errors on any or all devices connected to the network.

4. Always disconnect power before opening the E-800A.

5. Handle the E-800A Control Panel display window with care.

The E-800A display window is made of glass. If the glass breaks and the liquid crystal inside leaks out, avoid contact with it. If you do come in contact with the liquid crystal, wash it off with soap and water immediately.

6. Avoid pressing the surface of the display window.

Applying pressure to the display window will cause it to change color.

7. Use a soft cloth moistened with isopropyl or ethyl alcohol to clean the surface of the E-800A display window.

Other solvents, such as water, may damage the polarizer on the display window.

Preface

8. Use care when handling parts of the E-800A as some edges on the unit may be sharp. For example, be careful when:
 - Accessing the CD-ROM/ZIP drive (keep the drive door closed when not in use)
 - Plugging in cables at the back of the unit
 - Using the power switch to power on/off the unit

9. Follow standard ESD (electrostatic discharge) precautions while working on the internal components of the E-800A.

Static is always a concern when servicing electronic devices. It is highly unlikely that the area around the copier and the E-800A is static-free. Carpeting, leather-soled shoes, synthetic clothing fibers, silks, and plastics may generate a static charge of more than 10,000 volts. Static discharge is capable of destroying the circuits etched in silicon microchips, or dramatically shortening their life span. By observing standard precautions, you may avoid extra service calls and save the cost of a new board.

When possible, work on a ground-connected antistatic mat. Wear an antistatic grounding strap, grounded at the same place as the antistatic mat. If that is not possible:

- Attach a grounding strap to your wrist. Attach the other end to a good ground.
 - When you unpack the E-800A from the carton for the first time, touch a metal area of the copier to discharge the static on your body.
 - Before you remove the E-800A side panel and before you handle internal components, touch a metal part of the E-800A.
 - Leave new electronic components inside their antistatic bags until you are ready to install them. When you remove components from an antistatic bag, place them on a grounded antistatic surface, component-side up.
 - When you remove an electronic component, place it into an antistatic bag immediately. Do not walk across a carpet or vinyl floor while carrying an unprotected board.
10. Handle printed circuit boards by their opposing edges only, and avoid touching the contacts on the edge of the board.
 11. Never set a cup of coffee—or any liquid—on or near the E-800A or the copier.

Tools you will need

Tools you will need

To install or service the E-800A, you should bring the following tools and parts:

- ESD wrist grounding strap and antistatic mat
- Wire cutters
- #0 and #1 Phillips head screwdrivers (non-magnetic)
- PROM extractor

You should also bring this guide and any technical notes for the E-800A.

Chapter 1: Introduction

The E-800A Color Server adds computer connectivity and highly efficient Adobe PostScript 3 color printing capability to color copiers. It is optimized for high-speed network communications, processing, rasterization, and printing of continuous tone color and monochrome pages.

Features

The E-800A, as an integral part of a color printing system, enables users to:

- Send images over AppleTalk, TCP/IP, and Novell networks to print on E-800A supported devices.
- Spool print jobs and select a printing priority for each job. Users can control spooled print jobs sent to the E-800A with remote user software running on networked PC and Mac OS computers.
- Print files in color, grayscale, and black and white.
- Use the copier as a high-resolution color scanner with Fiery Scan software.
- Use 136 resident fonts (126 Adobe Type 1 PostScript, and 10 TrueType), plus two Adobe Multiple Master fonts used for font substitution when printing PDF files. Fiery Downloader or any third-party LaserWriter downloader, such as the Adobe Font Downloader, can be used to download additional fonts.
- Use resident fonts. The customer can download additional fonts as needed.
- Use built-in ColorWise™ color management and NetWise™ network features.

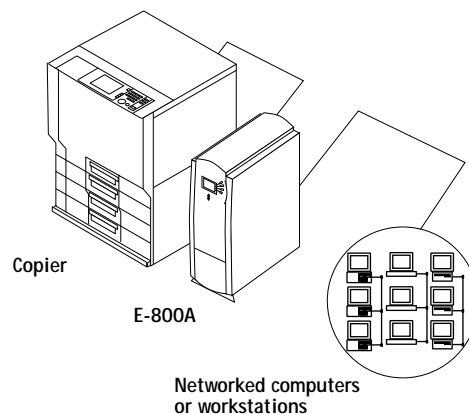

FIGURE 1-1 E-800A printing system

The E-800A is one of several imaging products engineered and manufactured by Electronics For Imaging.

1 Introduction

How the E-800A operates

The E-800A enables the customer to use a color copier as a printer and scanner. Users can print to the E-800A from networked PCs running Microsoft Windows, from networked Mac OS computers, and from networked UNIX workstations running TCP/IP.

The E-800A custom-designed boards and system software are responsible for efficient image processing and printing controls. The main functions of E-800A components and software are described below.

The E-800A uses specialized circuit boards, the motherboard and the copier interface board to process image data for printing and scanning images.

The motherboard includes a 500MHz CPU which controls the image data transfer to and from the copier interface board and runs the interpreter. The interpreter rasterizes the page description file and then compresses the image pattern into memory using compression technology.

The interpreter outputs compressed raster data through the image frame buffer memory to the E-800A copier interface board. The copier interface board decompresses the image data and sends it to the copier through the copier interface cable. The raster data supplied to the laser in the copier charges the drum and renders the final image on paper at full copier engine speed.

High-speed DIMMs (dual in-line memory modules) on the motherboard hold the image data during printing. The E-800A is configured with 320MB of memory.

When Fiery Scan™ uses the copier as a scanner, the E-800A acquires RGB (red, green, and blue) image data from the copier, stores it in memory, and transmits it to the computer that requested the scan.

1 Print options

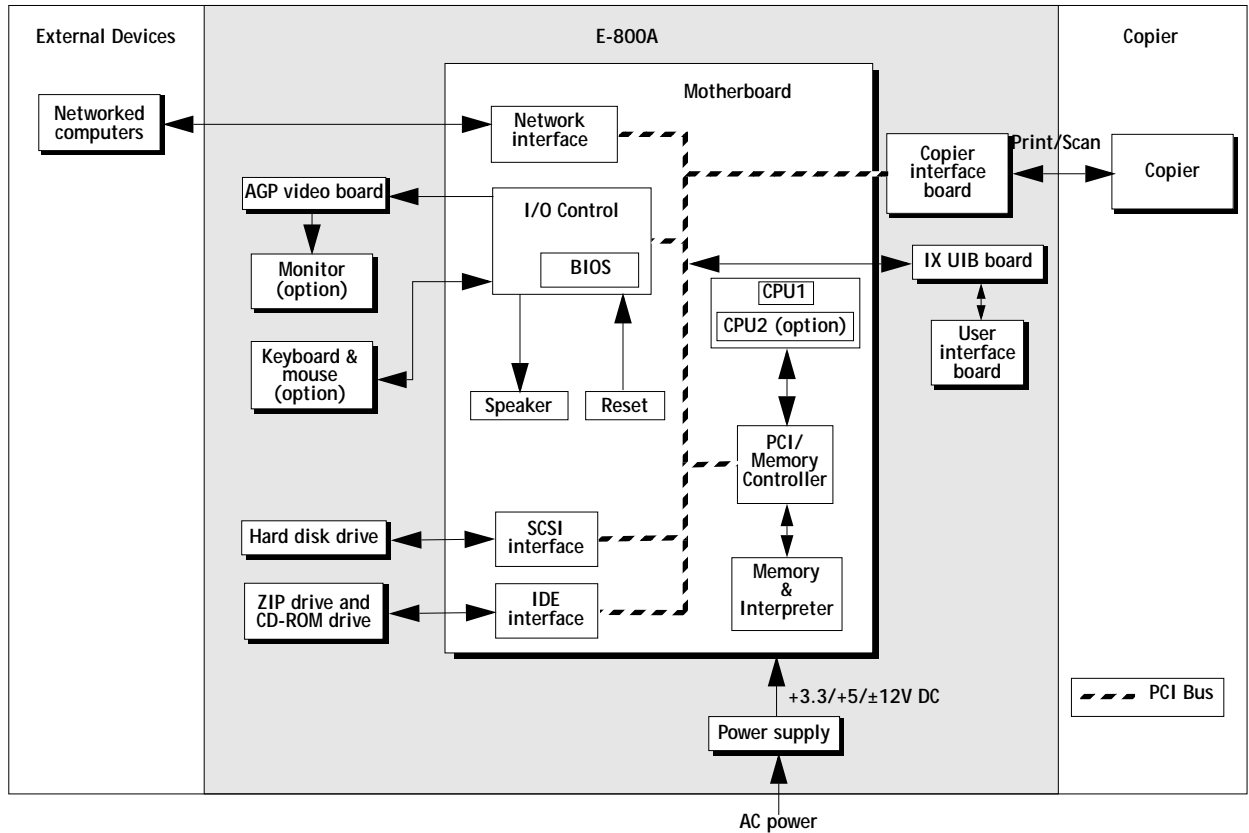

FIGURE 1-2 E-800A functional diagram

Print options

The E-800A's efficient capabilities allow users to use a variety of applications to create and print pages of text and/or images.

Printing over a network allows E-800A users to print documents directly from applications in which they were created. In addition, the E-800A offers an efficient way to print files that have been saved in PostScript, EPS (Encapsulated PostScript), or PDF (Portable Document Format). These files can be downloaded directly to the E-800A using Fiery Downloader™, one of the remote utilities for use with the E-800A.

User software

The following user software is provided on the User Software CD.

Adobe PS Printer Driver	Enables users to print to the E-800A from Windows 95/98, Windows NT 4.0, and Mac OS computers; also supports special E-800A and PostScript 3 features.
PostScript Printer Description files (PPDs)	Files for use with the PostScript printer driver that allows the E-800A to appear in popular applications' Print and Page Setup dialog boxes. The E-800A PPD provides information about the E-800A and the particular copier model to the application and printer driver.
PostScript Screen Fonts (for Mac OS only)	PostScript screen fonts for the 136 PostScript printer fonts installed on the E-800A (126 Adobe Type 1 and 10 TrueType).
Fiery Downloader	Enables the user to print PostScript files, Encapsulated PostScript (EPS) files, and Portable Document Format (PDF) files directly to the E-800A without opening the application in which they were created. Fiery Downloader also enables the user to manage the printer fonts installed on the E-800A.
Fiery Spooler (Mac OS only)	Enables the user to view the order and priority of print jobs, customize printer settings for jobs, delete jobs, and move jobs between queues. The user can also use it to view job accounting information.
Fiery Scan	Plug-in modules for Photoshop that enable the user to scan images from the copier directly into the application.
Command WorkStation software	Enables the operator to control the E-800A functions from Windows 95/98 and Windows NT 4.0 workstations. For more information on the Command WorkStation, see the <i>Job Management Guide</i> .
Color management files	ColorSync and ICM color management files that enable the user to maintain consistent color from original artwork to the colors displayed on the monitor to the printed output.
Color reference files	Reference pages that users can print to view the range of colors available on your E-800A. For the most predictable color results, refer to these pages when defining colors in applications.

1 User software

ColorWise Pro Tools	Enables the customer to use calibration and color management tools. It also enables the user to edit and download ICC profiles.
Fiery Link	Enables the customer to monitor the status of connected E-800A servers.
Calibration files	Includes measurements files and targets that you can use with ColorWise Pro Tools.

Fiery WebTools

The E-800A can support Internet or intranet access with Fiery WebTools, which include Status, WebSpooler, Installer, WebLink, WebSetup, and WebDownloader. For more information on WebTools, see the user documentation.

2

Installation sequence

Chapter 2: Preparing for Installation

This chapter includes the following information:

- Summary of the installation sequence
- Checking the customer site
- Unpacking the E-800A
- E-800A front and back overview

Installation sequence

Familiarize yourself with Chapters 2 and 3 of this guide before you attempt an installation. The installation sequence described in this chapter is designed to make your job as easy as possible. Installation problems are easier to avoid and diagnose if you proceed from the component to the system level and verify functionality at each stage. Figure 2-1 on page 2-2 outlines the recommended installation procedure for connecting the E-800A to the copier.

Because the E-800A is a node on the customer's computer network, make sure you coordinate your scheduled installation with the network administrator at the customer site. Refer the network administrator to the *Configuration Guide* for network setup information.

2 Preparing for Installation

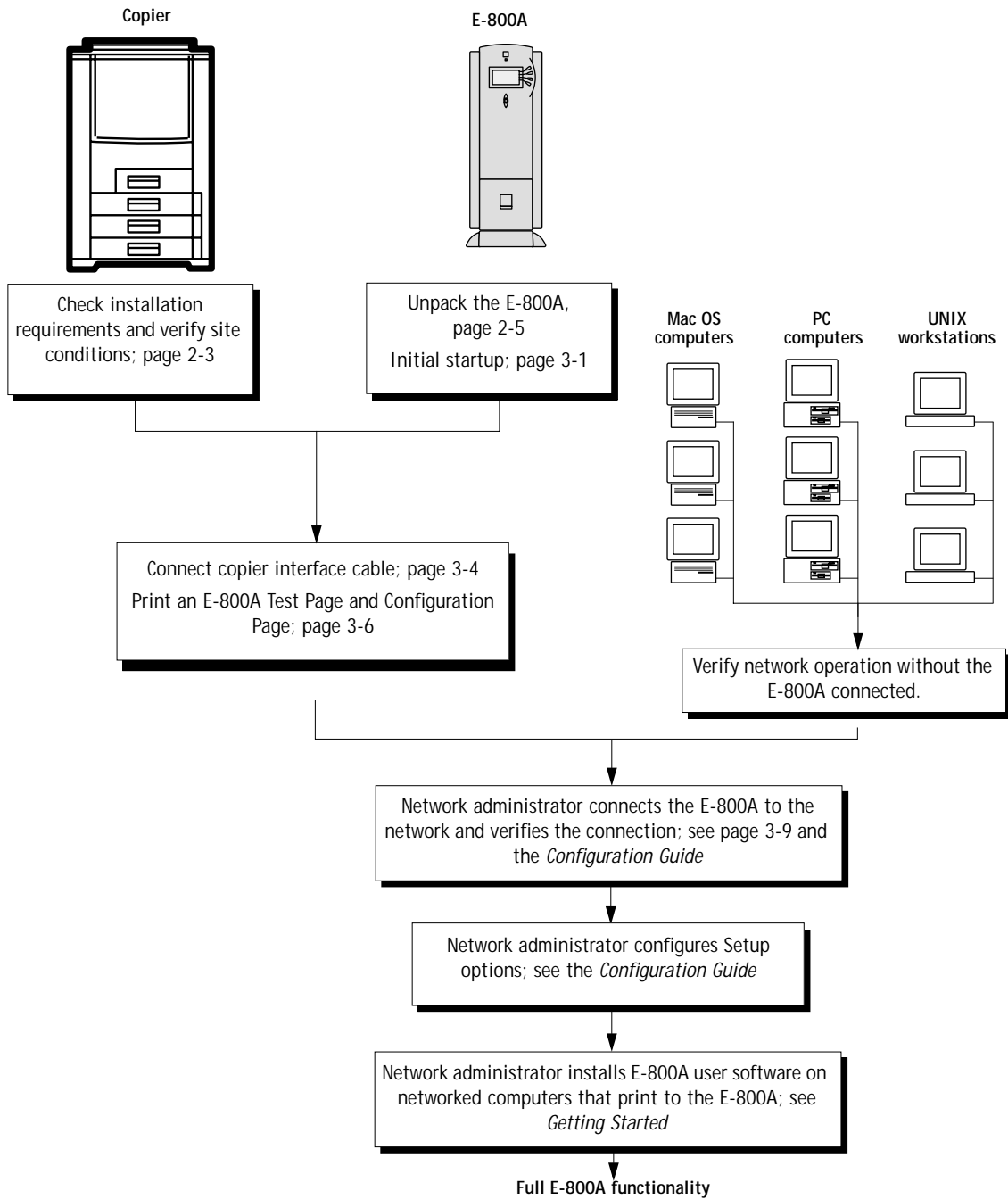

FIGURE 2-1 Recommended installation steps and references

2

Checking the customer site

Checking the customer site

Before you install the E-800A, check site conditions and inform the customer of any installation requirements.

Copier model

- What copier model is installed?
- Is there space near the copier for the E-800A?
Make sure that there is space for the E-800A. You may need to move the copier out from the wall for easier access to the connectors.
- Does the copier require service or adjustments?
Copy the copier color test page before you install the E-800A.
If the copied image indicates that the copier needs adjustment, inform the customer. After getting approval, complete the copier service needed.

Power

- Is there a dedicated grounded electrical outlet near the copier for the E-800A?
Locate the grounded electrical outlet that will supply power to the E-800A. You should not run the E-800A and the copier on the same circuit. Use a surge suppressor for the E-800A.
 - *Do not* use a 3-prong adapter in a 2-hole ungrounded outlet.
 - *Do not* use an extension cord.
 - *Do not* plug the E-800A into a circuit with heating or refrigeration equipment (including water coolers).
 - *Do not* plug the E-800A into a switchable wall outlet. This can result in the E-800A being turned off accidentally.

Network

- What is the network cable and connection type?
 - Unshielded twisted pair (10BaseT/100BaseT)
 - Optional Token Ring (shielded twisted pair or unshielded twisted pair)?
- Is the network connection ready and tested for E-800A installation?
To verify that the network is functioning before you attach the E-800A:
 - Ask the network administrator to print a document on a shared printer over the network.

2

Preparing for Installation

- Ask the network administrator to verify the computer and network requirements as specified in *Getting Started*.

System contact person

- Will the person responsible for the computers and the network be available at the time set for installation? Get a name as a contact.

Setting customer expectations

If the site is ready, installation takes about one hour. The customer should be informed of the following:

- Some nodes on the network may be unavailable for up to one hour.
- The copier may be unavailable for up to one hour.
- The network administrator needs to be available during the installation for network connectivity.

Equipment downtime and impact on the network can be minimized if the network administrator installs a network connector for the E-800A and confirms network functionality with the connector in place before the date scheduled for the E-800A installation.

- The network administrator should have a networked computer available during the installation. The appropriate software should already be installed. Documentation for the networked computer and the network operating software should be available.
- The network administrator should install the user software shipped with the E-800A (user documentation is also included) onto networked PC and Mac OS computers that will print to the E-800A.

NOTE: This guide covers E-800A hardware installation and service. It provides general information on connecting the E-800A to the customer's network. Network setup and configuration information goes beyond the scope of this guide. For network setup and configuration information, the network administrator should use the *Configuration Guide*.

2

Unpacking the E-800A

Unpacking the E-800A

The E-800A is assembled and shipped from the factory in a box that includes all necessary cables and documentation, as shown in Figure 2-2 on page 2-6.

TO UNPACK THE E-800A

1. Open the E-800A Color Server box and remove the packing material.
Save the original boxes and packing materials. If you need to transport the E-800A at a later date, the original box and packing material will ensure safe shipment.
2. Remove the contents from the top container. Inspect the contents for visible damage. The top container should include the following items:
 - Bags containing one copier interface cable and an AC power cable.
 - Interface extender board
 - Media package (includes a package of user documentation and software).

NOTE: A service kit containing system software is provided separately.
3. Give the media package to the customer or the network administrator.
Let the customer or network administrator know that in order to take full advantage of the E-800A, the user software must be installed on computers that will print to the E-800A.
4. Set aside the remaining components from the top container.
5. Remove the top container and any packing materials.
Set aside the packing material and note the orientation of the E-800A inside the shipping container in case you need to repack it later.
6. Carefully lift the E-800A out of the box.
If you notice shipping damage to any E-800A component, be sure to save the shipping container in case the carrier needs to see it. Call the carrier immediately to report the damage and file a claim, then call your authorized service/support center. Be ready to furnish the serial number printed on the back of the E-800A.

2 Preparing for Installation

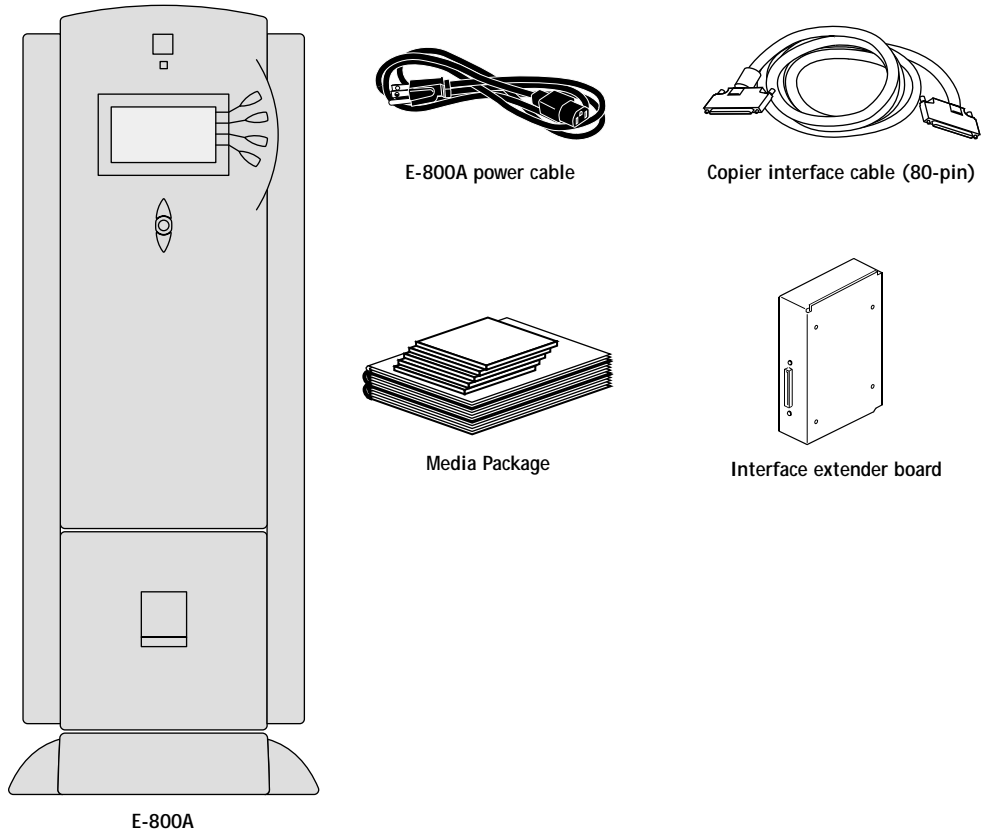

FIGURE 2-2 Contents of E-800A shipping box

2 E-800A panels

E-800A panels

Once you have unpacked the E-800A, you can familiarize yourself with the front and back of the E-800A before you install it.

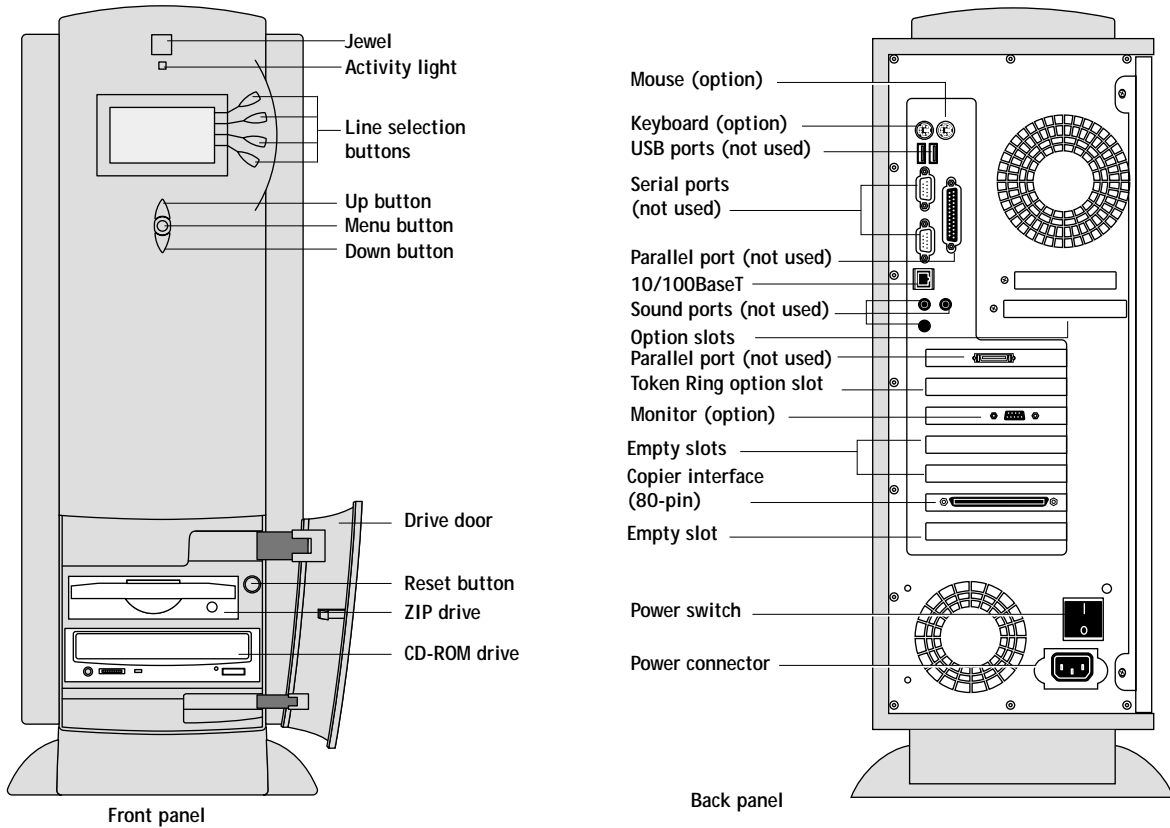

FIGURE 2-3 Front and back panels

3 Preliminary checkout

Chapter 3: Connecting the E-800A

After you unpack or service the E-800A, power on the system and allow diagnostics to run before you connect the E-800A to the copier and the network. Diagnostics run automatically during startup to check the E-800A for internal problems.

The interface extender board must be installed on the copier before the E-800A can be connected to the copier. See Appendix B for the procedure to install the interface extender board.

Preliminary checkout

The following procedure describes how to connect power to the E-800A.

TO CONNECT POWER AND START THE E-800A

1. Connect the E-800A power cable to the power connector at the back of the E-800A (see Figure 3-1).
2. Make sure the E-800A power switch is in the off position (press 0), and then connect the other end of the E-800A power cable to a wall outlet.

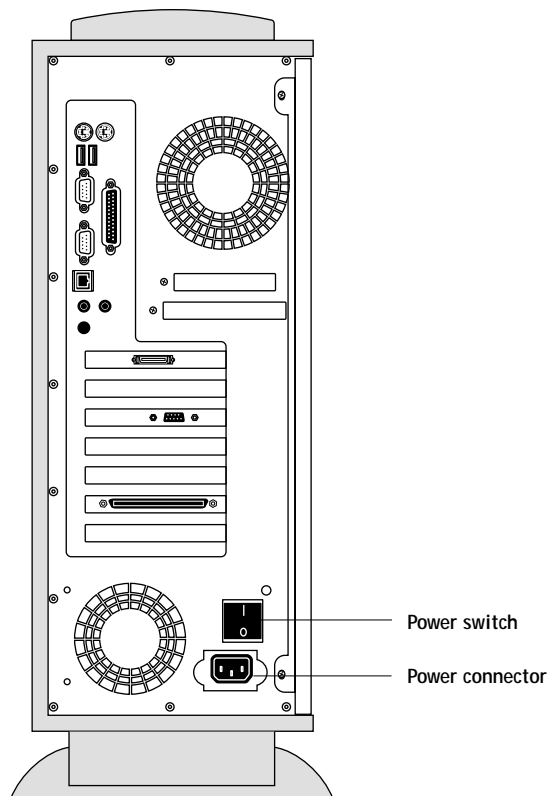

FIGURE 3-1 E-800A power

3

Connecting the E-800A

3. Power on the E-800A using the power switch on the back panel. The power supply automatically senses the correct voltage.

If you need the language of the system to be in English, skip steps 4 through 8 and allow the startup to proceed to Idle as described in step 9. Initial startup could take up to 30 minutes to complete.

4. When diagnostics begin, press the fourth line selection button to open the Service menu if you need the system to be in a language other than English.

If you do not press the fourth line selection button before the end of the diagnostics (about 20 seconds), the E-800A continues startup and you must restart the system and try again.

5. Select Install Software from the service menu.

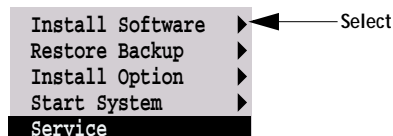

6. At the following screen, insert the appropriate language-specific system CD from the media pack in the CD-ROM drive.

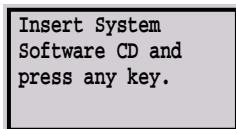

If an error message appears, verify that the correct System Software CD is inserted.

7. When the following screen is displayed, make sure "Yes" is displayed and then select OK. The installation process will begin immediately.

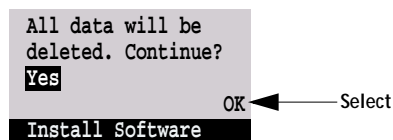

Wait while the E-800A Control Panel displays screens that indicate that the software is being installed.

3 Preliminary checkout

8. At the message "To complete installation, remove CD and recycle power," remove the System Software CD and power off and on the system using the power switch on the back panel.

After the system software is installed, the E-800A will initialize the system and will also run diagnostics and create a system backup.

9. To confirm that the E-800A is operating properly, allow E-800A startup to proceed without interruption while you watch the Control Panel. Do not press any buttons on the Control Panel.

Be sure to allow the system to boot completely. Initial startup could take up to 30 minutes to complete.

10. Allow the system to proceed to Idle to confirm that the E-800A is operating correctly.

Before the system reaches the Idle screen, it creates a backup of the system software configuration. If at some point you need to restore the default configuration of the system software, see "Retrieving backup system software" on page 4-56.

Once the E-800A reaches the idle state, you are ready to connect it to the copier and the network. Setup options should be configured after making these connections. It is the network administrator's responsibility to configure Setup according to the network and user environment. Refer the network administrator to the *Configuration Guide* for Setup information.

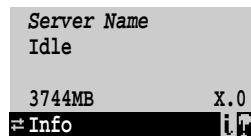

NOTE: The message Check power and cable may appear in the Control Panel during the startup process. Once the E-800A is connected to the copier, the message should no longer be displayed.

11. Following a successful startup, shutdown the E-800A from the Functions menu and then power off using the power switch.

3

Connecting the E-800A

Connecting to the copier

After completing the preliminary checkout, install the interface extender board on the copier as described in Appendix B of this guide.

After installing the extender board on the copier, connect the E-800A to the copier. The E-800A communicates with the copier through one cable from the copier interface board to the connector on the extender board.

TO CONNECT THE E-800A TO THE COPIER

1. Power off the E-800A and the copier.
You may need to get permission from the network administrator or supervisor to turn off the power to the copier.
2. Connect the E-800A copier interface cable to the extender board on the copier.
3. Connect the other end of the cable to the E-800A copier interface connector (see Figure 3-2).

Tighten the screws completely on both ends of the copier interface cable.

3 Connecting to the copier

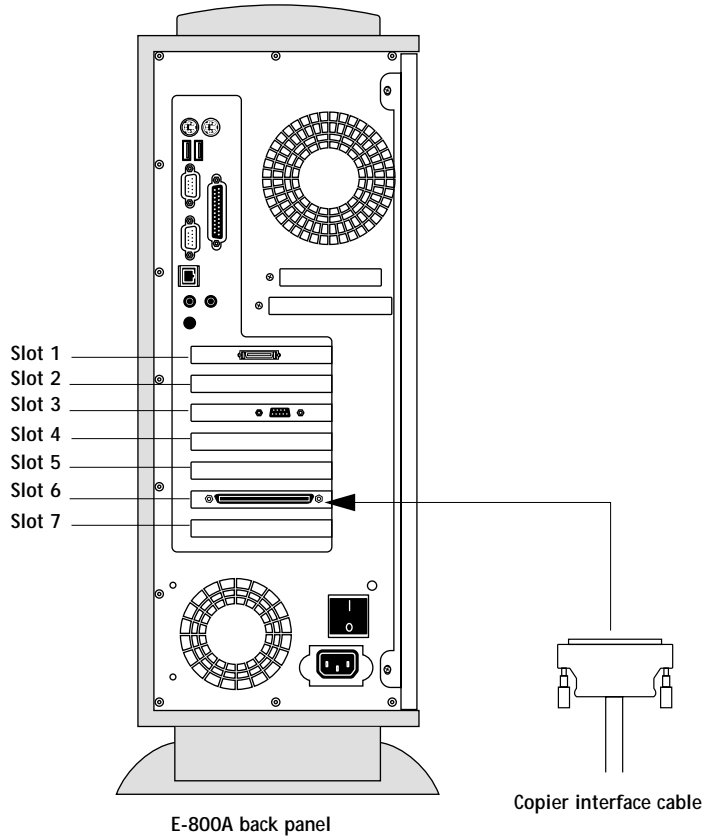

FIGURE 3-2 Copier interface cable connection

3

Connecting the E-800A

Verifying the connection

After you connect the E-800A to the copier, print the Test Page as well as the Configuration Page to verify that the connection between the E-800A and the copier is good.

Printing the E-800A Test Page and Configuration page

Before connecting the E-800A to the network, print the Test Page and the Configuration page.

- **Test Page**—printing the Test Page verifies that all components of the E-800A-to-copier interface work. The Test Page is a color file that resides on the E-800A hard disk drive.
- **Configuration page**—printing the Configuration page can be helpful during installation, setup, and service. After installation of the E-800A and before any default settings are changed, you can obtain a record of the defaults by printing the Configuration page.

After the physical connection to the network is made, the network administrator can customize Setup options according to the network and user environment. Using the Configuration page as a guide can help speed up this process. For more information, see the *Configuration Guide*.

Before you perform any service procedure, you should print the E-800A Configuration page, if possible, so that you are prepared to return the settings to their former configuration, if necessary.

TO PRINT THE TEST PAGE

1. Power on the copier and allow it to warm up.
2. Power on the E-800A from the power switch on the back panel.
Messages appear on the Control Panel as the E-800A runs through its startup diagnostics.
3. Before proceeding, make sure that the copier is not in use. The E-800A Info screen should read Idle.

3

Verifying the connection

4. At the Idle screen, press the menu button once (see “Using the Control Panel” on page 3-11). The Functions menu appears as shown in Figure 3-3.

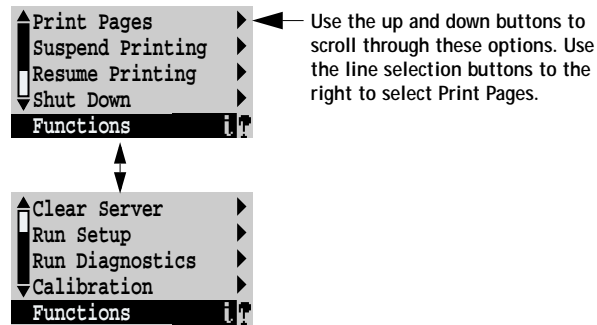

FIGURE 3-3 Functions menu

5. Press the line selection button to the right of Print Pages and then select Test Page.

The E-800A sends the Test Page to the copier and displays the RIP and Print status screens so you can monitor the job.

6. Examine the quality of the Test Page from the copier.

If the Test Page prints, you know that the E-800A print engine is functional and that the connection between the E-800A and the copier/printer is good. When you examine the Test Page, keep in mind that:

- All color patches should be visible, even though they may be very faint in the 5% and 2% range.
- Each color's patch set should show uniform gradation from patch to patch as the color lightens from 100% to 0%.

Poor image quality may indicate a need to calibrate the system or service the copier/printer. Information on the Test Page includes the date and time of the last calibration so the Test Page can be kept for future reference. For more information, see the *Reference Guide*.

3

Connecting the E-800A

TO PRINT A CONFIGURATION PAGE

1. Power on the copier and allow it to warm up.
2. Power on the E-800A from the power switch on the back panel.
Messages appear on the Control Panel as the E-800A runs through its startup diagnostics.
3. Before proceeding, make sure that the copier is not in use. The E-800A Info screen should read Idle.
4. At the Idle screen, press the menu button once (see “Using the Control Panel” on page 3-11). The Functions menu appears as shown in Figure 3-4.

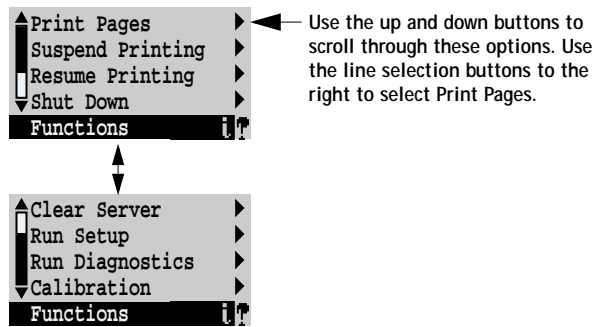

FIGURE 3-4 Functions menu

5. Press the line selection button to the right of Print Pages and then select Configuration page.

The E-800A sends the Configuration page to the copier and displays the RIP and Print status screens so you can monitor the job.

3

Installing additional options

Installing additional options

If the customer has purchased additional E-800A options, install those before connecting the E-800A to the network. For installation instructions, see the documentation included in each option kit.

After installing options, print the Test Page to verify that the system is operating properly. Checking the installation at each stage makes it easier to pinpoint the cause of problems should they occur.

Connecting to the network

The motherboard in the E-800A has an external 10/100BaseT Ethernet network connector for a twisted pair cable (see Figure 3-5). For additional network information, see the *Configuration Guide*.

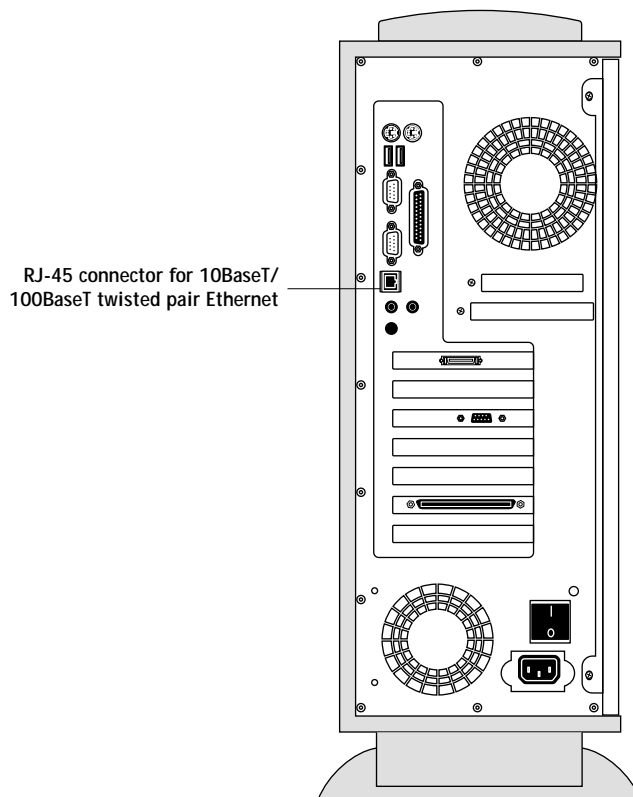

FIGURE 3-5 E-800A network connector

Token Ring compatibility is available with the optional Token Ring kit (see the documentation included with that kit for more information).

3

Connecting the E-800A

TO CONNECT A TWISTED PAIR CABLE TO THE E-800A

Twisted pair (unshielded twisted pair cable or 10BaseT/100BaseT) uses a RJ-45 connector that connects to the back of the E-800A (see Figure 3-5 on page 3-9).

1. Power off the E-800A before connecting it to any network device.

If the system has just finished processing, wait 5 seconds after the system reaches the idle state before using the power switch to power off the unit.

2. Connect the network cable to the RJ-45 connector on the back of the E-800A.

A Category 5 unshielded twisted pair cable (UTP) network cable must be used for 100BaseT.

3. Configure Setup options.

It is the network administrator's responsibility to configure Setup according to the network and user environment. Refer the network administrator to the *Configuration Guide* for Setup information.

4. After configuring Setup options, verify the network connection.

Once the network connection has been made and the E-800A has the correct Setup configuration, the E-800A should be available on the network.

The network administrator should perform any additional network setup, verify the network connection, verify that the E-800A appears in the list of printers, and print a few test documents from a networked computer that will use the E-800A. (See the *Configuration Guide* for more information.)

3 Using the Control Panel

Using the Control Panel

This section describes the Control Panel on the front of the E-800A. Once you install the E-800A and verify that it powers up correctly, you can use the Control Panel to access and monitor different functions of the E-800A.

The current status of the E-800A and Setup information are displayed in the E-800A display window. E-800A activity can be monitored in the display window, and functions of the E-800A (such as printing a Test Page and installing or updating system software) can be controlled using the buttons on the Control Panel.

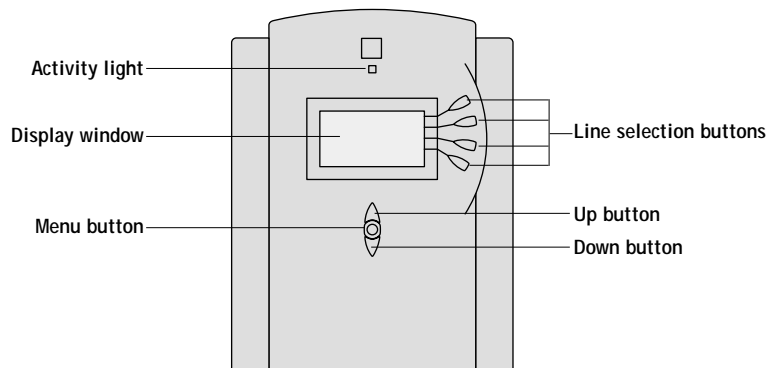

FIGURE 3-6 The E-800A Control Panel

3

Connecting the E-800A

Activity light

The activity light indicates current E-800A activity. If the light is:

Flashing or solid red	There is an error causing printing to be disabled. The activity light also flashes red briefly during startup.
Solid green	The E-800A is idle or starting up.
Flashing green	The E-800A is processing or printing a job.
No light	The E-800A is powered off.

Buttons

Line selection buttons	There are four line selection buttons on the right side of the Control Panel. Use these buttons to select the command displayed on the corresponding line of the display window. A special character (▶) appears in the display window next to a button when it is available.
Up and down buttons	Use these buttons to scroll to different screens in multi-screen lists, to select Setup options from a list, and to select alphanumeric characters.
Menu button	Press this button to view other display screens. There are several different display screens, showing different types of information about the E-800A.

3 Using the Control Panel

Control Panel screens and icons

When the E-800A is in Print mode, pressing the menu button cycles among four screens: three status screens (Info, RIP, and Print) and the Functions menu (see Figure 3-7). When the E-800A is idle, pressing the menu button cycles between the Info screen and the Functions menu.

The bottom line of the screen displays the name of the current screen with the icon for that screen highlighted. Icons for other active screens are also displayed but are not highlighted.

The E-800A screens display the following information:

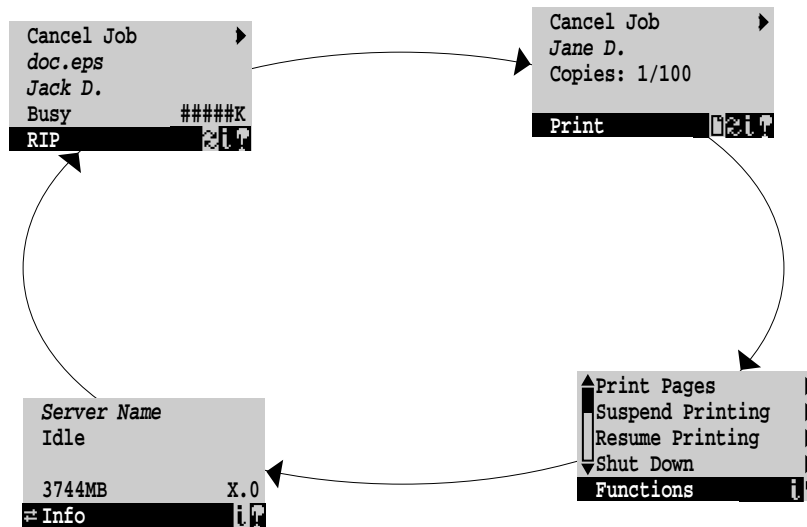

FIGURE 3-7 Control Panel screens during printing

If an error occurs, the Alert screen is displayed with a message describing the error.

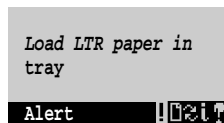





FIGURE 3-8 Alert screen

3

Connecting the E-800A

The display window screens and icons are:

	Alert Status	If there is a problem during printing or processing, the Alert Status screen is activated, displaying an error message. For information on user error messages, see the <i>Printing Guide</i> .
	Print Status	When the E-800A is printing, the Print Status screen is activated. This screen displays the following: Cancel Job—Press the top line selection button to cancel the job currently printing. User name—The name of the user who sent the job that is currently being processed. Pages/Total—The number of copies of the current page that have been printed so far, and the total number of copies of this page that were requested.
	RIP Status	When the E-800A is processing a job, the RIP Status screen is activated. This screen displays the following: Cancel Job—Press the top line selection button to cancel the job currently processing. The E-800A cancels the job before printing begins. Document name—The name of the document currently processing. User name—The name of the user who sent the job that is currently being processed. Kilobytes—The amount in kilobytes of the job that has been processed so far.

3

Using the Control Panel



Info Status

The Info Status screen displays information about the server's current activity, and software version. This screen is always active, and it appears in the display window when no other screen is selected. It displays the following information:

Server Name—The E-800A name as it is configured in Setup.

Status—The current status of the E-800A. The E-800A status can be: Idle, Initializing, Busy, Processing, or Printing.

Number of MB—The space in megabytes available on the E-800A hard disk.

Version—The system software version running on the E-800A.



Functions

The Functions screen also is always active, but it appears in the display window only when the user has pressed the Menu button to select it. Use the up and down buttons to scroll through the list of menu command options. Press the line selection button to the right of a command to select it.



Network

The Network icon appears in the bottom left corner of the display window when the E-800A is communicating over the network. The Network icon can appear while any screen is displayed.

3

Connecting the E-800A

Functions menu

The Functions menu allows you to perform a variety of administrative functions that do not affect print jobs of other users. Use the up and down buttons to scroll through the list of options. Press the line selection button next to the option you want to select.

The following options are available from the Functions menu:

Print Pages—Enables you to print special pages from the E-800A. You can print the following pages from the submenu that appears:

- Test Page—Enables you to confirm that the E-800A-to-copier interface is functioning properly. The Test Page provides sample images that can be used to troubleshoot the E-800A. The following information is also listed: Server name, printer model, output profile, calibration information, RGB source, rendering style, date and time printed, CMYK simulation, simulation method, and compression information.
- Configuration—Prints the current server and device configuration. This includes information about all current Setup settings, calibration profile, and the Ethernet address of the E-800A. The Configuration page also provides version information for the BIOS chip and information on any options installed in the E-800A.
- Job Log—Prints the log of the last 55 jobs by default. For more information about the job log, see the *Printing Guide*.
- Control Panel Map—Prints the Setup screen help pages. These pages are useful when navigating through the different Setup screens.
- Color Charts—Prints the color reference charts. These pages include swatches of the RGB, CMY, and PANTONE colors available from the E-800A.
- Font List—A list of all fonts resident on the E-800A hard disk.

Suspend Printing—Disconnects the E-800A from the copier. This option interrupts the current print job so you can use the copier to make copies; after you make the copies you can select Resume Printing and the copier continues processing and printing jobs.

Resume Printing—Connects the copier to the E-800A so you can resume printing after interrupting the print job to make copies (used with Suspend Printing).

3

Using the Control Panel

Shut Down—When you select this option, you can choose from the following:

- Restart Server—resets the E-800A server software but does not reboot the entire system. Network access to the E-800A is temporarily interrupted and all currently processing jobs are aborted and might be lost.
- Shut Down System—Shuts down all E-800A properly so that you can power off the system using the power switch on the back panel. You should always select this option before powering off the system or using the reset button.
- Reboot System—Shuts down all E-800A activity properly and then restarts.

NOTE: A reset button on the front panel is also available and should only be used after selecting Shut Down System first.

Clear Server—Clears all jobs from the server queues. It also clears the Job Log, all jobs saved on the server hard disk drive, and the index of all archived jobs.

Run Setup—Allows you to access the Setup options in order to configure the network and printing environment. Typically it is the network administrator's responsibility to configure Setup according to the network and user environment. Setup is required the first time the E-800A is powered on and after E-800A system software is installed. See the *Configuration Guide* for a list of options and detailed descriptions of each Setup option.

Run Diagnostics—When you select this option, you can choose the following:

- Test I/F board—Runs diagnostics on the E-800A copier interface board.

Select the line selection button next to the option.

Calibration—Allows the customer to calibrate the E-800A using AutoCal. See the *Color Guide* for more information.

3

Connecting the E-800A

Shutting down and restarting the E-800A

The E-800A will generally be left on all the time at the customer site. Remember that when the E-800A is powered off, network access to the copier is interrupted.

You should shut down the E-800A when you need to service it or the copier, and before you remove or attach any cables to the E-800A. Shut down the E-800A when changing the copier's toner in order to prevent the fan from drawing toner into the E-800A.

TO SHUT DOWN THE E-800A

1. Make sure that the E-800A Info screen reads Idle.

When Printing or Ripping appears on the Control Panel the E-800A is currently processing a job. Idle appears in the Info screen when the E-800A is finished processing the job.

2. At the Idle screen, press the menu button once to display the Functions menu.

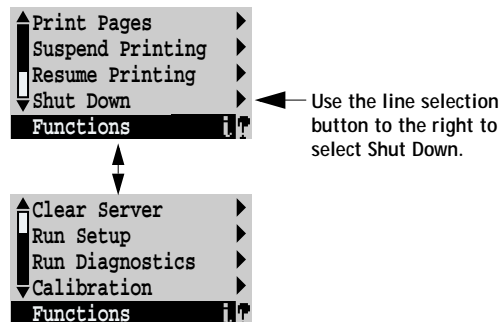

FIGURE 3-9 Shut Down command in the Functions menu

3. Select Shut Down from the Functions menu.
4. At the next screen, select Shut Down System.
The message It is now safe to power off the system.... is displayed.
5. Power off the E-800A using the power switch on the back panel (press 0).

TO RESTART THE E-800A

1. If the E-800A is already on, ensure that it is not receiving, processing, or printing a document.

When Printing or Ripping appears on the E-800A Control Panel, the E-800A is currently processing a print job. Wait until the job is complete and Idle appears in the Info screen.

2. Press the menu button once, then select Shut Down from the Functions menu and select Reboot System.

4

Overview

Chapter 4: Service Procedures

Generally, the E-800A requires no regular service or maintenance. Use the procedures in this chapter to inspect, remove, reseal, and replace major hardware components as well as to install system software.

Overview

This chapter includes information on servicing the following components:

- Boards
- Cables
- Motherboard components (DIMMs, CPU, BIOS chip, Battery)
- Fans (front and back panel)
- Power supply
- HDD (hard disk drive)
- ZIP drive
- CD-ROM drive
- Front panel components

See Figure 4-1 on page 4-2 for an overview of components. Replacement parts are available from your authorized service representative.



When performing the service procedures described in this chapter, follow the precautions listed in “Precautions” on page xiii.

NOTE: The tools required to service the system are listed in “Tools you will need” on page xv.

System software service

E-800A system software is installed on the HDD at the factory. A backup of the system software resides on a separate partition on the HDD. You can retrieve a backup of the system software using the Restore Backup function in the Service menu. In addition system software is also provided on a CD. Use the System Software CD when you:

- Replace the HDD
- Upgrade to a more recent version of the system software

For information on how to install system software, see “E-800A system software service” on page 4-55.

4 Service Procedures

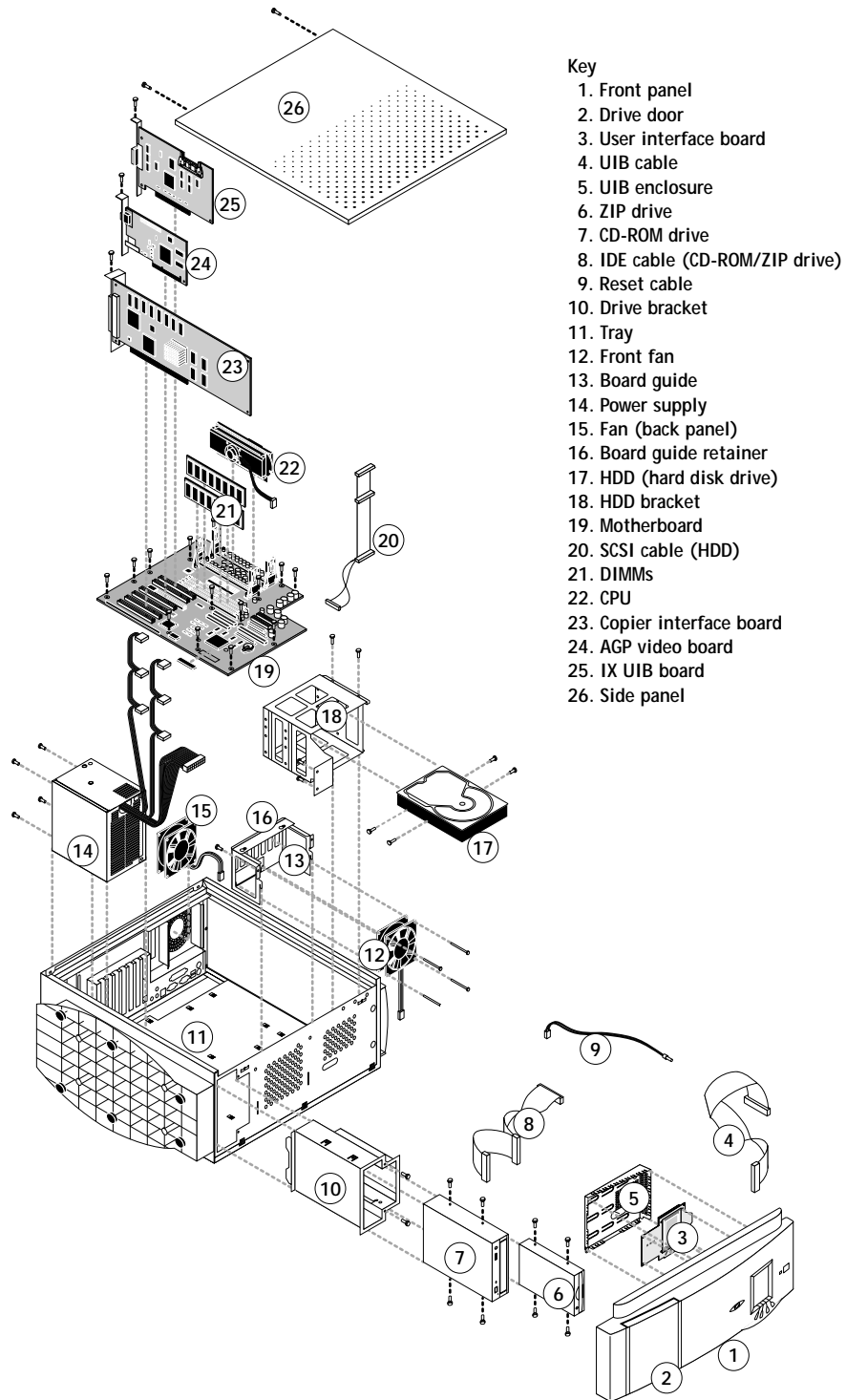

FIGURE 4-1 Exploded view of E-800A components

4

Accessing E-800A internal components

Accessing E-800A internal components

If the E-800A is powered on, make sure to shut down the system before you gain access to the E-800A's internal components. Always use the following procedures when opening the E-800A for inspection or service. Remember that when the E-800A is powered off, network access to the copier is interrupted.

TO SHUT DOWN THE E-800A



Always verify that the E-800A is not being used before you power off or restart it. Make sure that the E-800A is not ripping or printing a job.

1. Make sure that the E-800A Info screen reads Idle.

When Printing or Ripping appears on the Control Panel the E-800A is currently processing a job. Idle appears in the Info screen when the E-800A is finished processing the job.

2. At the Idle screen, press the menu button once to display the Functions menu.

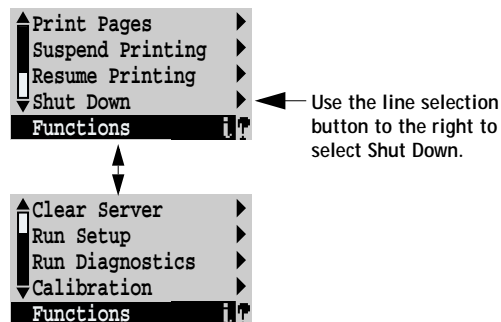

FIGURE 4-2 Shut Down command in the Functions menu

3. Select Shut Down from the Functions menu.
4. At the next screen, select Shut Down System.
The message It is now safe to power off the system... is displayed.
5. Power off the E-800A using the power switch on the back panel (press 0).
6. Disconnect all cables from the back panel of the E-800A.

Always obtain permission from the network administrator before you take the E-800A off the network.

4

Service Procedures

TO OPEN THE E-800A

1. Make sure you have powered off the E-800A and removed all the cables from the back.
2. Remove the two screws that secure the side panel to the tray.
3. Lift off the side panel (see Figure 4-3).

Press on the front edge of the side panel as you slide the panel off the tray.

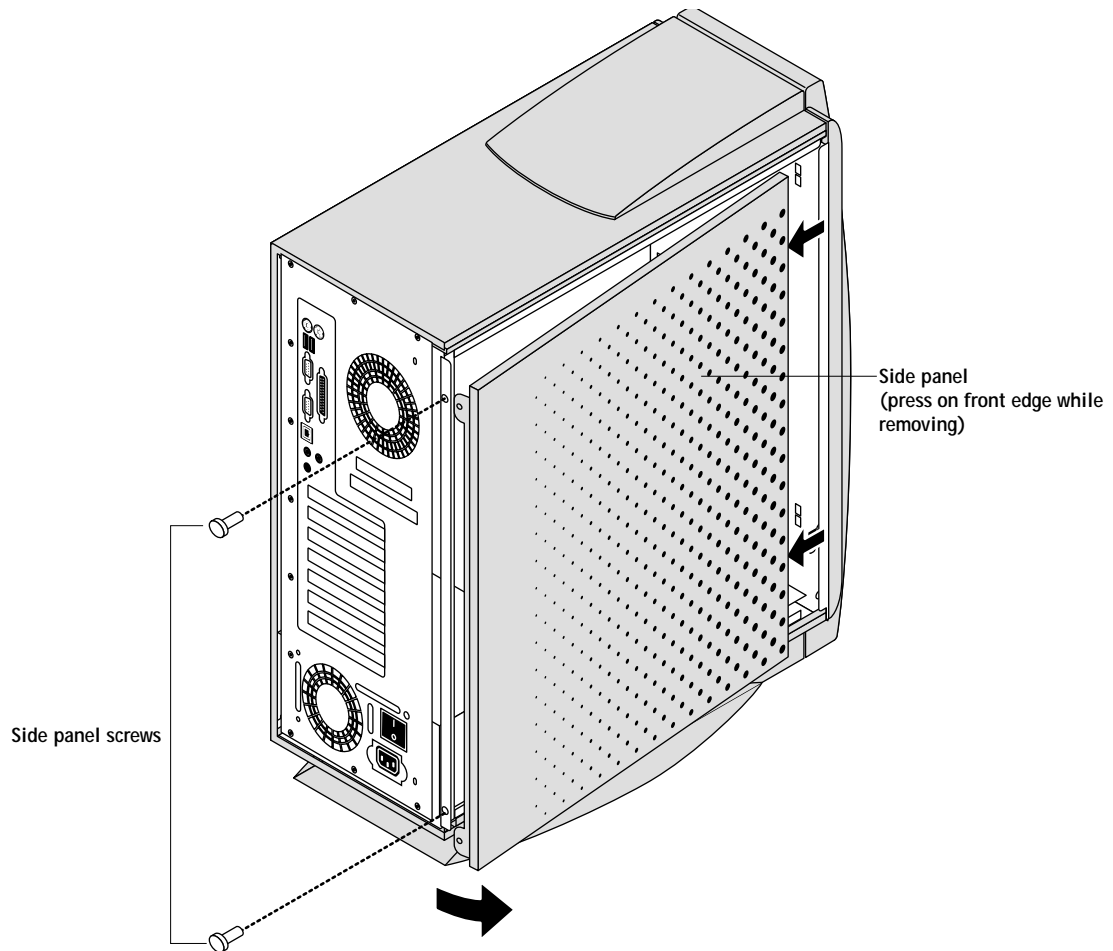

FIGURE 4-3 Removing the E-800A side panel

4. The E-800A internal components are now accessible. Attach an ESD wrist strap before handling internal parts.

The E-800A is shipped from the factory with a standard board configuration, as shown in Figure 4-4 on page 4-5. If optional components have been installed, see the documentation that came with the specific kit.

4

Accessing E-800A internal components

NOTE: To service components inside the tray, position the E-800A so that it is resting on its side and the components inside the tray are facing up.

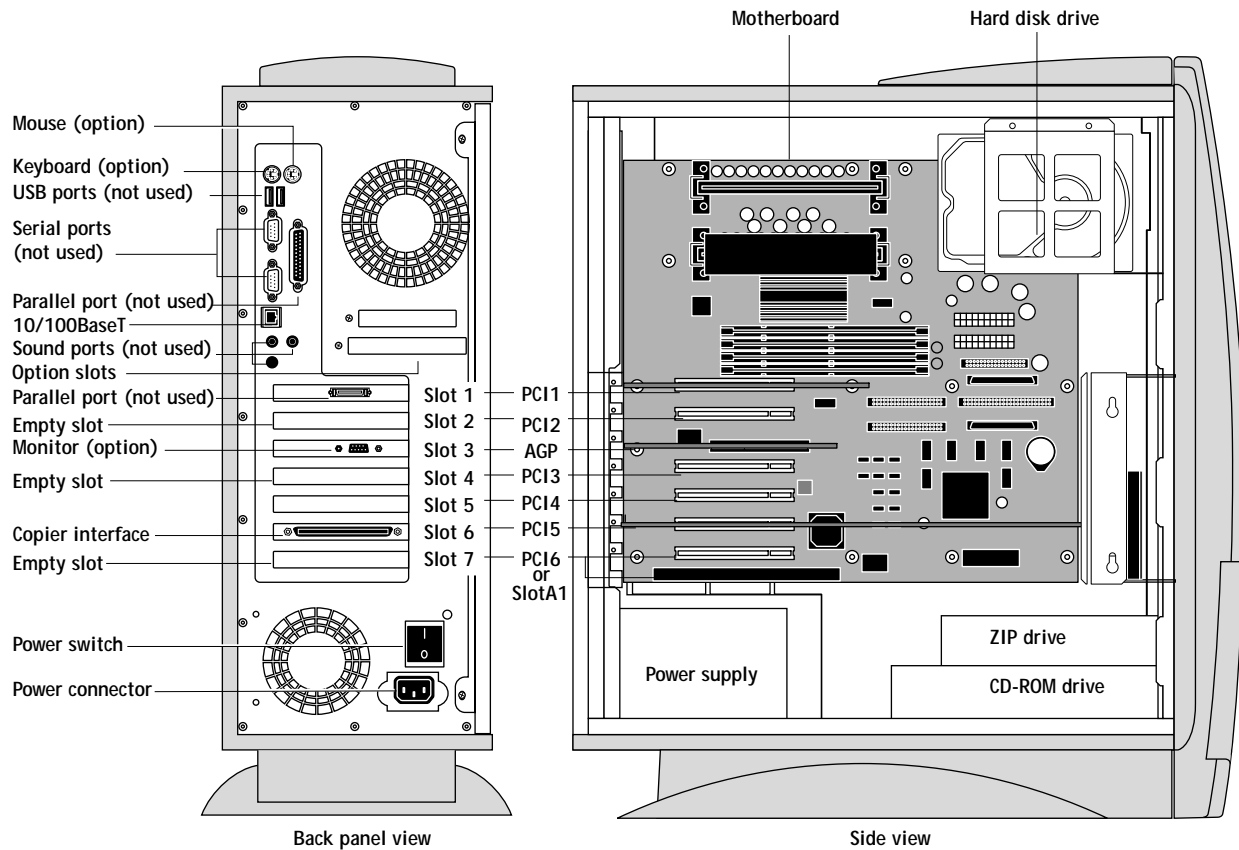

Motherboard connectors:
 PCI1—IX UIB board
 PCI2—Empty (reserved for Token Ring option)
 AGP—AGP video board
 PCI3—Empty
 PCI4—Empty
 PCI5—Copier interface board
 PCI6—Empty
 SlotA1—Empty

FIGURE 4-4 E-800A side view and back panel view

4

Service Procedures

Accessing front panel components

The following procedure describes how to remove the front panel in order to access the user interface board, the Control Panel buttons, CD-ROM/ZIP drive assembly, and the top front panel jewel. You do not need to remove the front panel in order to access other components inside the tray.

TO REMOVE THE FRONT PANEL

1. Remove the E-800A side panel as described on page 4-4.
2. Remove the UIB cable from connector J4 on the IX UIB board.
The other end of the UIB cable is connected to the user interface board inside the front panel.
3. On the inside front of the tray, squeeze the tabs that secure the front panel to the tray.
4. As you squeeze the tabs, gently rotate the front panel to the right to release the hooks from the tray.
5. Thread the UIB cable connector through the opening in the front of the tray to completely remove the front panel.

The front panel components are now accessible.

4

Accessing E-800A internal components

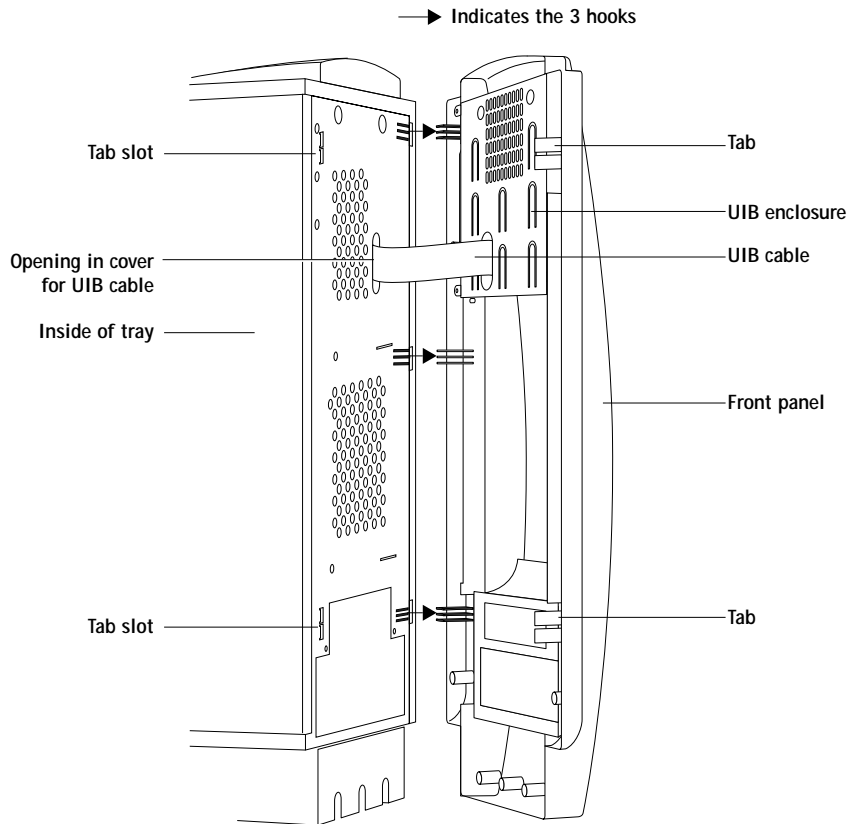

FIGURE 4-5 Removing the front panel

TO REPLACE THE FRONT PANEL

1. Make sure the UIB enclosure and all front panel components are installed correctly.
2. Thread the end of the UIB cable that connects to the IX UIB board through the opening in the front of the cover.
The other end of the cable should already be securely connected to the user interface board.
3. Connect the UIB cable to connector J4 on the IX UIB board.
When you connect the cable, be sure to snap the levers together to ensure that the connector is securely fastened.
4. Angle the front panel so that the three hooks on the edge of the front panel line up with the cutouts on the front of the cover (see Figure 4-5).
5. Rotate the front panel into the cover until you hear it snap into place.

4

Service Procedures

Checking E-800A internal connections

The most common causes of hardware problems are faulty and loose connections. Before you conclude that any board or component has failed, remove, inspect, and reseal all appropriate connections, and then verify that the problem still occurs.

TO CHECK BOARD AND CABLE CONNECTIONS



1. Before you touch any parts inside the E-800A, attach a grounding wrist strap. Touching the metal part of the power supply case inside the E-800A also discharges static electricity.
2. Position the E-800A so it is resting on its side and the internal components of the E-800A are facing up.
3. Inspect the E-800A boards for secure insertion into the motherboard. Press down firmly on each board to make sure it is securely installed.

Looking into the tray from the top, the standard board configuration includes the following (from top to bottom):

Connector PCI1—IX UIB board

Connector PCI2—Empty

Connector AGP—AGP video board

Connector PCI3—Empty

Connector PCI4—Empty

Connector PCI5—Copier interface board

Connector PCI6—Empty

Connector SlotA1—Empty

4. Inspect ribbon cables to see if they are intact.
Faulty ribbon cables are easily overlooked. Check the contact point between the cable and the connector to ensure that they have not separated. If a ribbon cable is suspect, substitute it with a tested cable.
5. Make sure that all E-800A ribbon cables and power cables are seated on connectors. See Figure 4-6 on page 4-9.
Cable connectors are keyed to fit only when properly oriented.
6. Check the front fan, back panel fan, CPU fan, and reset cable connections to the motherboard.
7. After tightening connections, if one or more E-800A components are still not getting power, see “Checking voltages” on page 4-40.

4

Checking E-800A internal connections

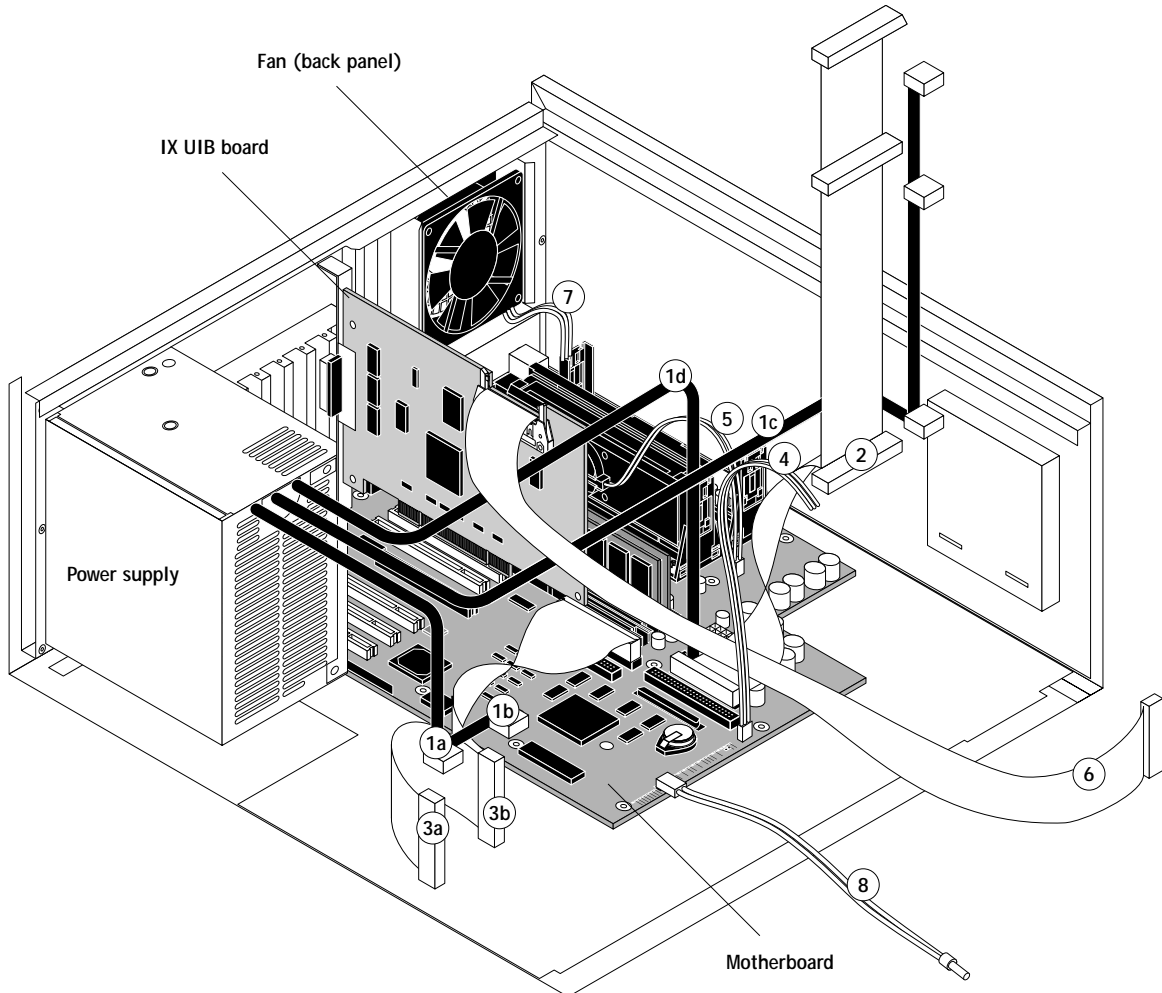

Cable key	From	To
1. Power supply cable	Power supply	a. 4-pin connector—CD-ROM drive b. 4-pin connector—ZIP drive c. 4-pin connector—HDD (hard disk drive) d. 20-pin connector—Motherboard (J18)
2. SCSI cable	Motherboard (Ultra.2 SCSI CH A connector)	HDD SCSI connector
3. IDE cable	Motherboard (Primary IDE connector)	a. CD-ROM drive b. ZIP drive
4. Front fan cable	Front fan	Fan connector on motherboard (FAN5)
5. CPU fan cable	CPU fan	Fan connector on the motherboard (FAN1)
6. UIB cable	UIB connector on the IX UIB board (J4)	User interface board (J1)
7. Back panel fan cable	Fan (back panel)	Fan connector on the motherboard (FAN3)
8. Reset cable	Motherboard (Reset pins on edge of board)	Switch in front of tray

NOTE: Cables not labeled are not used.

FIGURE 4-6 Cable connections in the E-800A

4

Service Procedures

TO CHECK MOTHERBOARD DIMM CONNECTIONS

1. Check that all DIMMs are locked. If any DIMMs have come loose, release and reseal them.
The DIMMs (dual in-line memory modules) on the E-800A motherboard are held in place by levers at each end. Sockets 1-4 on the motherboard hold the DIMMs.
2. To release a DIMM, push outward on the levers on each side of the DIMM.

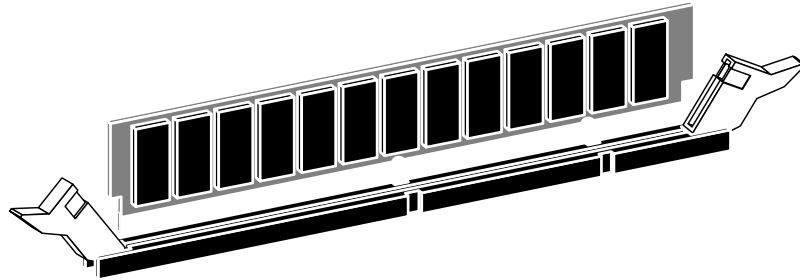

FIGURE 4-7 Releasing the DIMM levers

3. Slide the DIMM straight out of the socket.
4. To replace a DIMM, gently slide the DIMM straight into the socket and close the levers at each side to lock it into place.

Make sure that the levers close securely around the ends of the DIMM and that each DIMM is fully seated in its socket.

If you removed the DIMMs completely, note that DIMMs fit the socket only one way. The notches on the bottom of the DIMM should line up with the notches in the socket.

4

Restoring E-800A functionality after service

Restoring E-800A functionality after service

TO REASSEMBLE THE E-800A

1. Reseat all boards, cables, connectors, and other parts loosened or removed during inspection or service.
2. Place the E-800A in its standard operating position.
3. If you removed the front panel, replace it (see page 4-7).
4. Slide the side panel into the grooves along the edges of the tray (see Figure 4-8).

Be careful not to damage any ribbon cables; fold the ribbon cables inside the tray before replacing the side panel. Press on the front edge of the side panel during installation in order to compress the EMI gaskets around the edges of the tray.

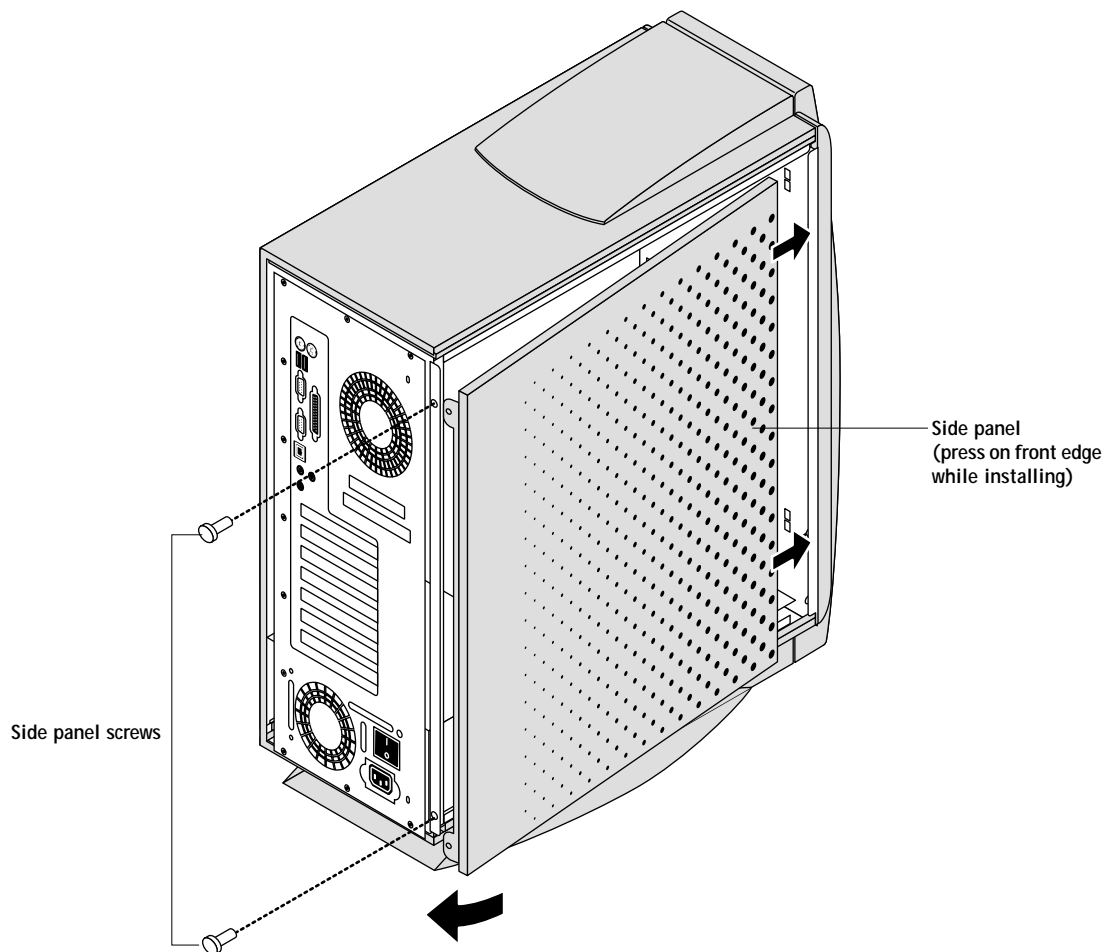

FIGURE 4-8 Replacing the side panel

4 Service Procedures

5. Replace the two screws that secure the side panel to the tray.

NOTE: Do not leave the E-800A side panel off after servicing. An airflow channel is created by the side panel and the fan. Leaving the E-800A open could reduce the operational life expectancy of internal E-800A components.

6. Connect any cables removed during service to the back of the E-800A.
7. Before you leave the customer site, verify E-800A operation as outlined in Figure 4-9.

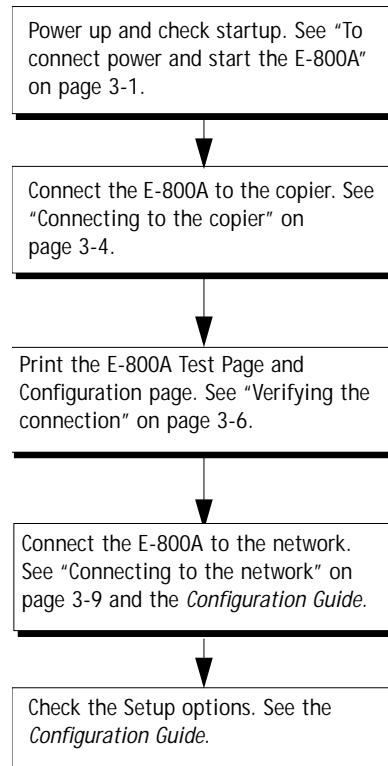

FIGURE 4-9 E-800A connection verification steps

4

Removing and replacing boards

Removing and replacing boards

This section includes procedures for removing and replacing the following boards:

- IX UIB board
- AGP video board
- Copier interface board
- User interface board
- Motherboard

For information on installing option boards, see the separate installation instructions provided with those boards.

4

Service Procedures

IX UIB board

The IX UIB board in motherboard connector PCI1 provides the interface between the user interface board in the front panel and the motherboard. A ribbon cable from the user interface board connects to J4 on the IX UIB board.

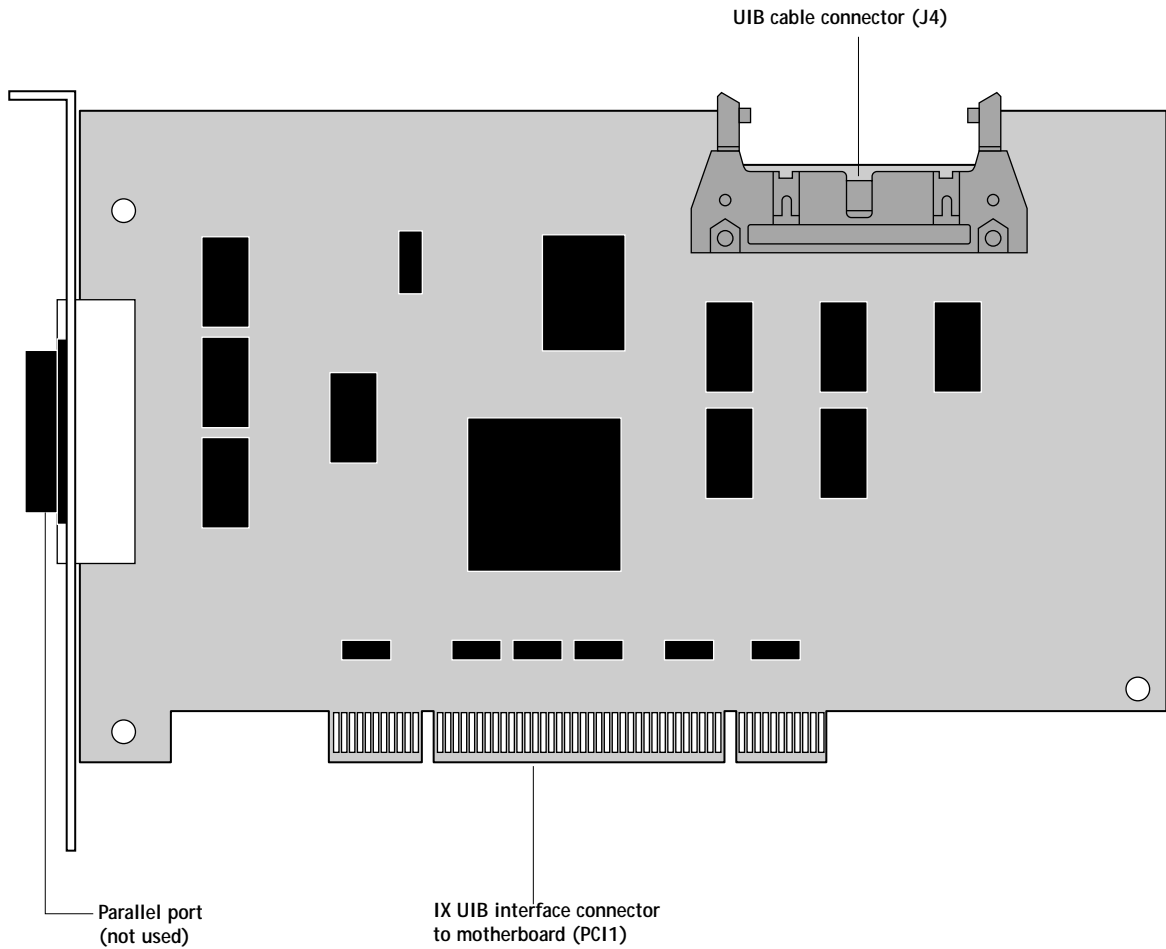

FIGURE 4-10 IX UIB board

4

Removing and replacing boards

TO REMOVE THE IX UIB BOARD

1. Power off and open the E-800A as described in "To shut down the E-800A" on page 4-3 and "To open the E-800A" on page 4-4.
2. Remove the UIB cable from connector J4 on the IX UIB board.
3. Remove the board mounting bracket screw from slot 1.
4. Remove the IX UIB board from the motherboard connector labeled PCI1.
Grasp the board at the front and back edge and gently pull the board straight out of its connector on the motherboard.
5. Place the board in an antistatic bag.

TO REPLACE THE IX UIB BOARD

1. Reseat the IX UIB board in connector PCI1 on the motherboard. The component side of the board should be facing down in the direction of the power supply.
The edge connector on the IX UIB board is keyed to fit the PCI connector only one way.
2. Attach the board mounting bracket screw to the IX UIB board bracket in slot 1.
3. Connect the UIB cable to connector J4 on the IX UIB board.
4. Reassemble the E-800A and verify its functionality (see the connection verification steps described in "Restoring E-800A functionality after service" on page 4-11).

4 Service Procedures

AGP video board

The AGP (Accelerated Graphics Port) video board installed in the E-800A provides connectivity to an optional monitor. The AGP video board has a 15-pin D connector (occupying slot 3 on the back of the E-800A tray) for attaching a monitor. The other connector on the board connects to the motherboard at the connector labeled AGP.

A Fiery Advanced Controller Interface option is available which includes a monitor.

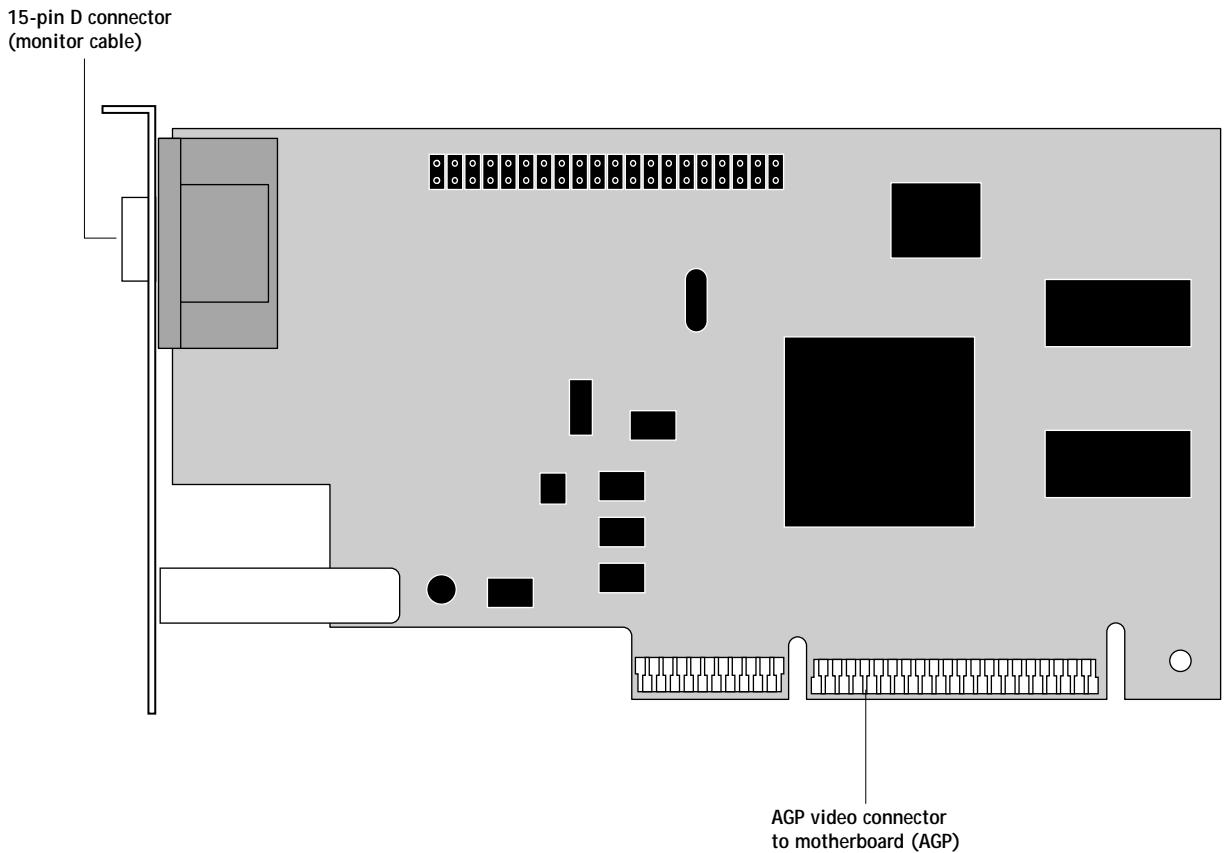

FIGURE 4-11 AGP video board

4

Removing and replacing boards

TO REMOVE THE AGP VIDEO BOARD

1. Power off and open the E-800A as described in "To shut down the E-800A" on page 4-3 and "To open the E-800A" on page 4-4.
2. Remove the board mounting bracket screw from slot 3.
3. Remove the AGP video board from the motherboard connector labeled AGP.
Grasp the board at the front and back edge and gently pull the board straight out of its connector on the motherboard.
4. Place the board in an antistatic bag.

TO REPLACE THE AGP VIDEO BOARD

1. Reseat the AGP video board in the connector labeled AGP on the motherboard. The component side of the board should be facing down in the direction of the power supply. The board connector is keyed to fit only one way when properly oriented.
2. Attach the board mounting bracket screw to the bracket in slot 3.
3. Reassemble the E-800A and verify its functionality (see the connection verification steps described in "Restoring E-800A functionality after service" on page 4-11).

4 Service Procedures

Copier interface board

The copier interface board in the E-800A (see Figure 4-12) provides the print interface between the E-800A and the copier.

The copier interface board is installed in connector PCI5 on the motherboard and takes up one back panel slot. The copier interface connector on one side of the board (occupying slot 6 on the back panel of the E-800A tray) connects to a cable that plugs into the copier.

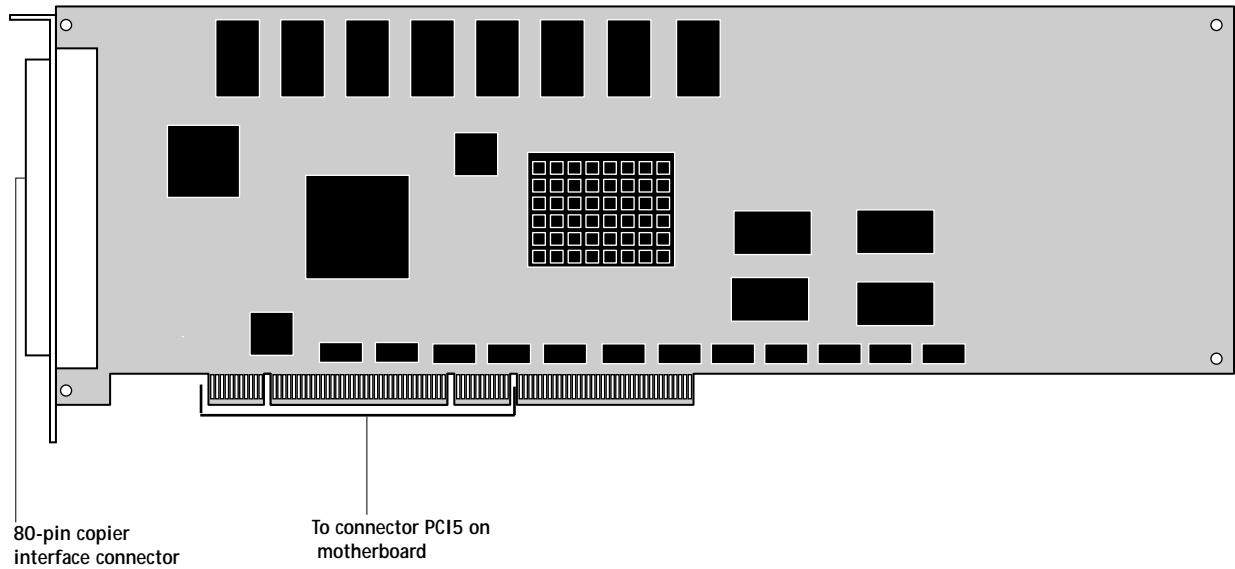

FIGURE 4-12 Diagram of copier interface board (component side)

4

Removing and replacing boards

TO REMOVE THE COPIER INTERFACE BOARD

1. Power off and open the E-800A as described in "To shut down the E-800A" on page 4-3 and "To open the E-800A" on page 4-4.
2. Make sure the copier interface cable connected to the back of the E-800A is removed.
3. Remove the two screws that secure the board guide retainer (see Figure 4-1 on page 4-2).
4. Remove the board mounting bracket screw from slot 6.
5. Remove the copier interface board from motherboard connector PCI5.
Grasp the board at the front and back edge and gently pull the board straight out of its connector on the motherboard.
6. Place the board in an antistatic bag.

TO REPLACE THE COPIER INTERFACE BOARD

1. Reseat the copier interface board in connector PCI5 on the motherboard. The component side of the board should be facing down in the direction of the power supply.
The copier interface board connector is keyed to fit only one way when properly oriented.
2. Attach the board mounting bracket screw to the copier interface board bracket in slot 6.
3. Replace the board guide retainer and secure it with two screws (see Figure 4-1 on page 4-2).
4. Reassemble the E-800A and verify its functionality (see the connection verification steps described in "Restoring E-800A functionality after service" on page 4-11).

4 Service Procedures

User interface board

The user interface board installed in the front panel of the E-800A (see Figure 4-13) provides the interface between the E-800A and the user. The front of the user interface board contains circuitry for the following:

- Activity lights (1 green and 1 red LED)
- Display window (LCD)
- Four line selection buttons
- Up and down buttons
- Menu button between the up and down buttons

A cable connector on the back of the board connects the user interface board to the IX UIB board.

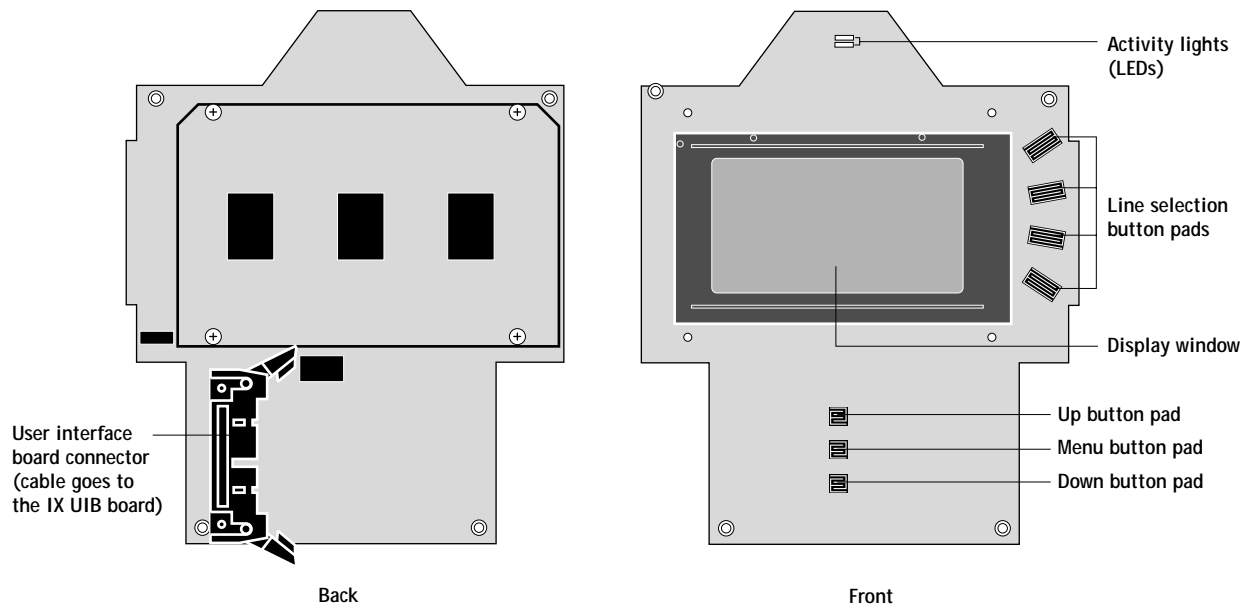

FIGURE 4-13 Diagram of the user interface board (back and front)

4

Removing and replacing boards

TO REMOVE THE USER INTERFACE BOARD

1. Power off the E-800A as described on "To shut down the E-800A" on page 4-3.
2. Remove the front panel from the E-800A cover as described in "To remove the front panel" on page 4-6.

Make sure the UIB cable is disconnected from the IX UIB board.

3. Remove the two screws that secure the UIB enclosure to the front panel.

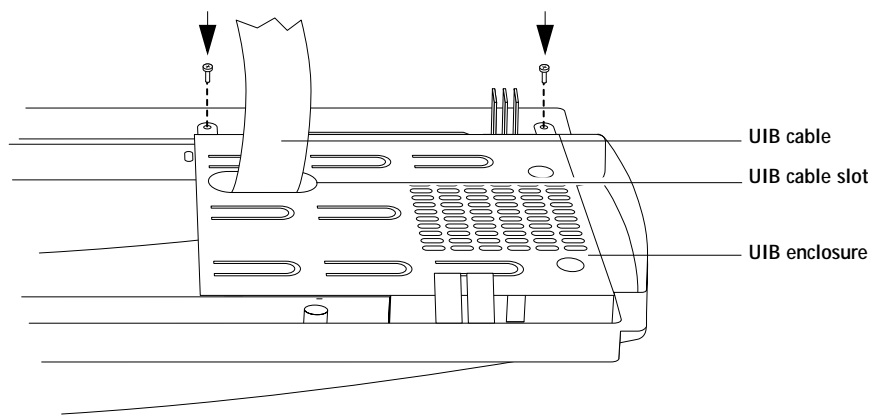

FIGURE 4-14 Removing the UIB enclosure

4. Carefully lift off the UIB enclosure. As you remove the UIB enclosure, thread the disconnected end of the UIB cable through the slot in the enclosure.
5. Disconnect the UIB cable from the connector on the user interface board and set aside the cable.

Press outward on the connector levers on each side of the connector (see Figure 4-15), then pull the connector free. Avoid pulling on the cable itself.

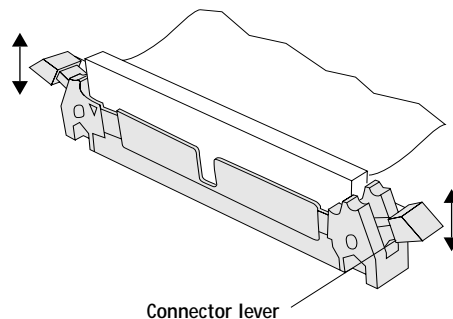

FIGURE 4-15 Detail of ribbon cable connector

4 Service Procedures

6. Gently push outward on the snap tabs that secure the user interface board to the inside of the front panel.
7. While pushing outward on the snap tabs, lift up one side of the user interface board and slide it out of the hooks (see Figure 4-16).

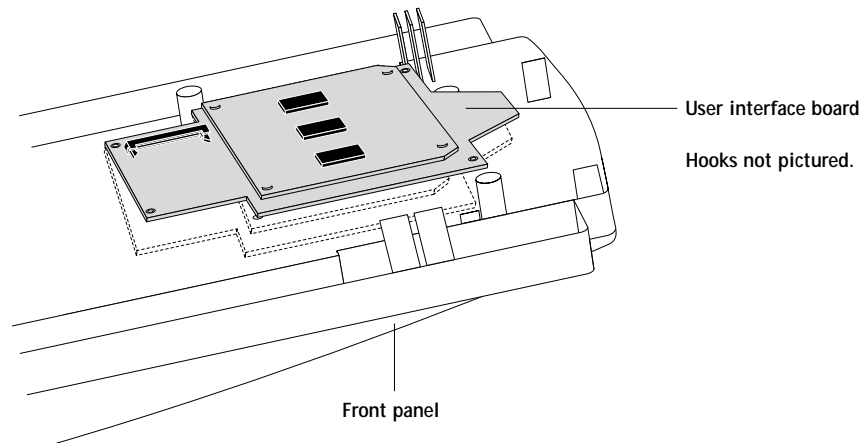

FIGURE 4-16 Removing the user interface board

8. Place the board in an antistatic bag.

TO REPLACE THE USER INTERFACE BOARD

1. Place the user interface board in the front panel at an angle so that the edge of the board fits under the hooks in the front panel (see Figure 4-16).
The board should be positioned so that the button pads on the front of the board line up with the buttons installed in the front panel.
2. Gently push the board into the snap tabs until it is securely seated in the front panel.
3. Attach the UIB cable to connector J1 on the user interface board.
When you connect the cable, be sure to snap the levers together to ensure that the connector is securely fastened.
4. Thread the UIB cable through the slot in the UIB enclosure.
5. Place the UIB enclosure over the user interface board and secure it with the two screws (see Figure 4-14 on page 4-21).
The edges of the UIB enclosure should fit inside the grooves in the front panel.
6. Replace the front panel as described in "To replace the front panel" on page 4-7.
7. Reassemble the E-800A and verify its functionality (see the connection verification steps described in "Restoring E-800A functionality after service" on page 4-11).

4

Motherboard

Motherboard

The E-800A motherboard has an Intel Pentium III 500MHz CPU that controls the image data transferred to and from the copier interface board. The motherboard also controls HDD functions and the communication between the E-800A and external devices. The motherboard has 4 DIMM sockets that hold one 256MB DIMM and one 64MB DIMM (see Figure 4-17 on page 4-24). The motherboard also includes:

- 6 32-bit PCI (Peripheral Component Interconnect) connectors
- AGP (Accelerated Graphics Port) video connector
- ISA (Industry Standard Architecture) connector

Removing the E-800A motherboard

The motherboard attaches to the side of the E-800A tray above the power supply. Before you remove the motherboard, you must remove:

- Board guide retainer (see Figure 4-1 on page 4-2)
- All boards installed on the motherboard
- All cables connected to the motherboard and IX UIB board (this includes the power cable, back panel fan cable, IDE cable, SCSI cable, and UIB cable)
- The HDD bracket (with HDD installed)
- Board guide

Procedures are included in this section for each of the requirements listed above. This section also includes motherboard information on the following:

- Replacing or upgrading memory
- Replacing a CPU
- Replacing the BIOS chip
- Replacing the battery
- Configuring jumpers

Take ESD precautions when handling the E-800A boards.

4 Service Procedures

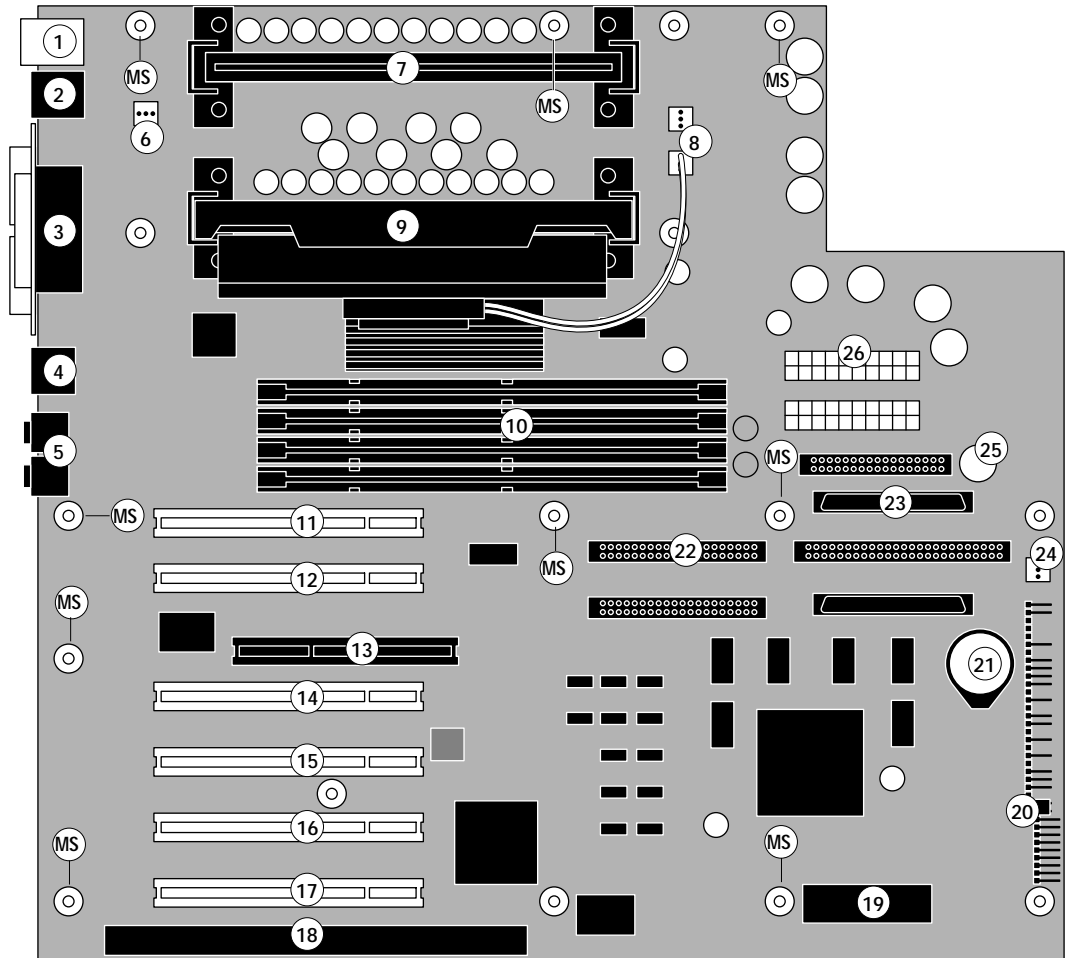

Key

- | | |
|--|---|
| 1. Keyboard and mouse connectors (options) | 15. Empty 32-bit PCI connector (PCI4) |
| 2. USB connectors (not used) | 16. Copier interface board connector (PC15) |
| 3. Serial ports/parallel port (not used) | 17. Empty 32-bit PCI connector (PCI6) |
| 4. 10/100BaseT connector | 18. Empty ISA connector (SlotA1) |
| 5. Sound ports (not used) | 19. BIOS chip (U67) |
| 6. Back panel fan connector (FAN3) | 20. Reset pins |
| 7. Additional CPU slot (CPU2) | 21. Battery (BT1) |
| 8. CPU fan connectors (FAN1 and FAN2) | 22. CD-ROM/ZIP IDE connector (Primary IDE) |
| 9. 500MHz CPU and fan (CPU1) | 23. HDD SCSI connector (Ultra.2 SCSI CH A) |
| 10. DIMMs (DIMM1-4) | 24. Front fan connector (FAN5) |
| 11. IX UIB board connector (PCI1) | 25. Speaker |
| 12. Empty 32-bit PCI connector (PCI2) | 26. 20-pin power connector (J18) |
| 13. AGP video board connector (AGP) | |
| 14. Empty 32-bit PCI connector (PCI3) | |
- MS—Mounting screws (9 screws)

Note: Connectors not listed above are not used.

FIGURE 4-17 Diagram of the E-800A motherboard

4

Motherboard

TO REMOVE BOARDS FROM THE MOTHERBOARD

1. Power off the E-800A and remove the side panel as described on page 4-4.
2. Remove the board mounting bracket screws for boards occupying slots 1, 3, and 6.
3. Remove the following boards from the motherboard:
 - IX UIB board in the connector labeled PCI1
Remove the UIB cable attached to connector J4 on the IX UIB board before removing the board.
 - AGP video board in the connector labeled AGP
 - Copier interface board in the connector labeled PCI5

NOTE: Remove the board guide retainer before removing the copier interface board (see "To remove the copier interface board" on page 4-19).

Place each board on an antistatic surface.

4. Remove the mounting bracket screws and any option boards installed in remaining connectors on the motherboard.
Grasp the board at the front and back edge and gently pull the board straight out of its connector on the motherboard. Place the boards on an antistatic surface.

TO REMOVE MOTHERBOARD CABLES

1. Remove the power cable attached to the 20-pin connector at J18 on the motherboard.
2. Remove the HDD SCSI cable from the SCSI connector (Ultra.2 SCSI CH A) on the motherboard.
3. Remove the ZIP/CD-ROM IDE cable from the Primary IDE connector on the motherboard.
4. Remove the back panel fan cable from the motherboard fan connector (FAN3).
5. Remove the front fan cable from the motherboard fan connector (FAN5).
6. Remove the reset cable from the reset pins on the edge of the motherboard.

4

Service Procedures

TO REMOVE THE MOTHERBOARD

1. If you are replacing the motherboard, remove the following from the motherboard:
 - Memory (see page 4-30)
 - CPU (see page 4-32)
 - BIOS chip (see page 4-34)
2. Remove the two screws that secure the board guide (see Figure 4-1 on page 4-2) and lift it out of the slots on the inside front of the tray.
3. Remove the HDD and bracket as described in "To remove the HDD" on page 4-44.
4. Remove the 9 mounting screws on the motherboard (see Figure 4-17 on page 4-24).
5. Lift the edge of the motherboard opposite the back panel connectors to remove the motherboard from the tray.

Four standoffs on the base of the tray also help to hold the motherboard in place. Gently pull up on the motherboard to release it from the standoffs. (Pinch the locks on any locking standoffs to release the board.)

4 Motherboard

6. Gently slide the motherboard out of the E-800A tray (see Figure 4-18).
Make sure the back panel connectors on the motherboard clear the tray as you remove the board. Make sure to avoid handling contacts and avoid using excessive force.

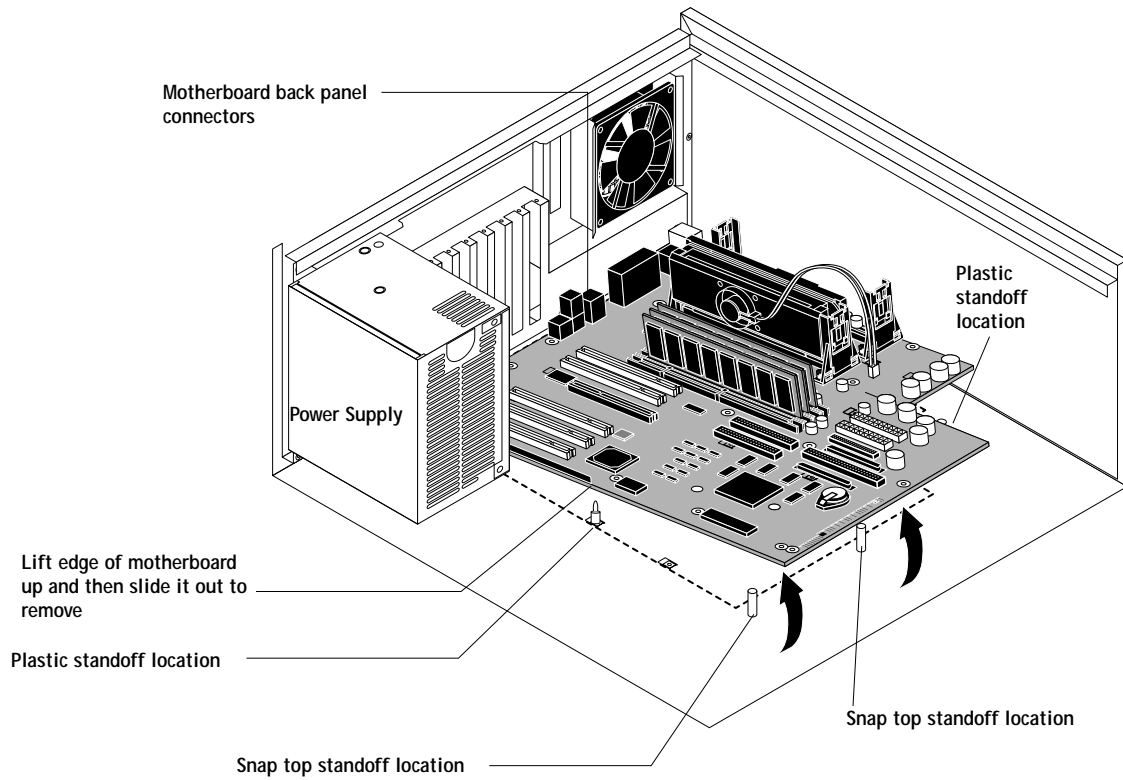

FIGURE 4-18 Removing the motherboard

4

Service Procedures

Replacing the motherboard

This section includes the procedures required to replace the E-800A motherboard. Spare motherboards ship without memory, CPU, and the BIOS chip. The memory, CPU and BIOS chip from the old board will need to be installed on the replacement motherboard.

TO REPLACE THE MOTHERBOARD

1. If you replaced the motherboard with a new board, replace the following components on the board:
 - Memory (see page 4-30)
 - CPU (see page 4-32)
 - BIOS chip (see page 4-34)
2. Angle the motherboard so the back panel connectors on the motherboard fit into the cutouts in the back of the tray. See Figure 4-18 on page 4-27.
3. Align the mounting holes on the edge of the motherboard (opposite the back panel connectors) with the standoffs located in the base of the tray (see Figure 4-18 on page 4-27).
4. Once the mounting holes in the motherboard are aligned over the standoffs, gently push the motherboard down to secure it to the tray.
5. Insert the 9 motherboard mounting screws to attach the motherboard to the tray but do not tighten them completely (see Figure 4-17 on page 4-24 for screw locations).
6. Tighten the 9 motherboard mounting screws.
Do not overtighten the screws; doing so could damage traces on the motherboard.
7. Replace the board guide and secure it with two screws (see Figure 4-1 on page 4-2).

TO REPLACE BOARDS

1. Replace the following boards in the appropriate motherboard connectors:
 - IX UIB board in the connector labeled PCI1
 - AGP video board in the connector labeled AGP
 - Copier interface board in the connector labeled PCI5

As you plug the board into the connector on the motherboard, make sure that the board connector is properly aligned with the connector on the motherboard.
2. Replace any option boards installed in remaining connectors on the motherboard.

4

Motherboard

TO REPLACE THE MOTHERBOARD CABLES

1. Connect the power cable to the 20-pin power connector J18 on the motherboard.
2. Connect the SCSI cable from the HDD to the SCSI connector (Ultra.2 SCSI CH A) on the motherboard.
3. Connect the IDE cable from the ZIP/CD-ROM drive to the Primary IDE connector on the motherboard.
4. Connect the back panel fan cable to the motherboard fan connector labeled FAN3.
5. Connect the front fan cable to the motherboard fan connector labeled FAN5.
6. Insert the reset cable onto the pins labeled RESET on the edge of the motherboard.
7. Connect the UIB cable to connector J4 on the IX UIB board.

TO COMPLETE AND VERIFY MOTHERBOARD INSTALLATION

1. Replace HDD and bracket as described in "To replace the HDD" on page 4-45.
2. Attach the board mounting bracket screws for boards occupying slots 1, 3, and 6. Press down firmly on the top of the board as you insert each screw.

NOTE: Make sure unused slots have slot covers installed. Uncovered slots reduce air flow and could cause the E-800A to overheat.
3. Press down on each cable connector and verify that all cables are attached properly.
4. Reassemble the E-800A and verify functionality (see the connection verification steps described in "Restoring E-800A functionality after service" on page 4-11).

Replacing parts on the motherboard

This section describes how to remove and replace DIMMs, CPU, BIOS chip, and the battery on the motherboard. Before performing any of these procedures, you must first power off the E-800A as described in “To shut down the E-800A” on page 4-3, and remove the side panel as described in “To open the E-800A” on page 4-4.

DIMMs

The E-800A motherboard has four DIMM sockets (DIMM1-4). Currently the E-800A is configured for 320MB with one 256MB DIMM installed in socket 1 and one 64MB DIMM installed in socket 2.

Approved DIMMs are available from your service representative.

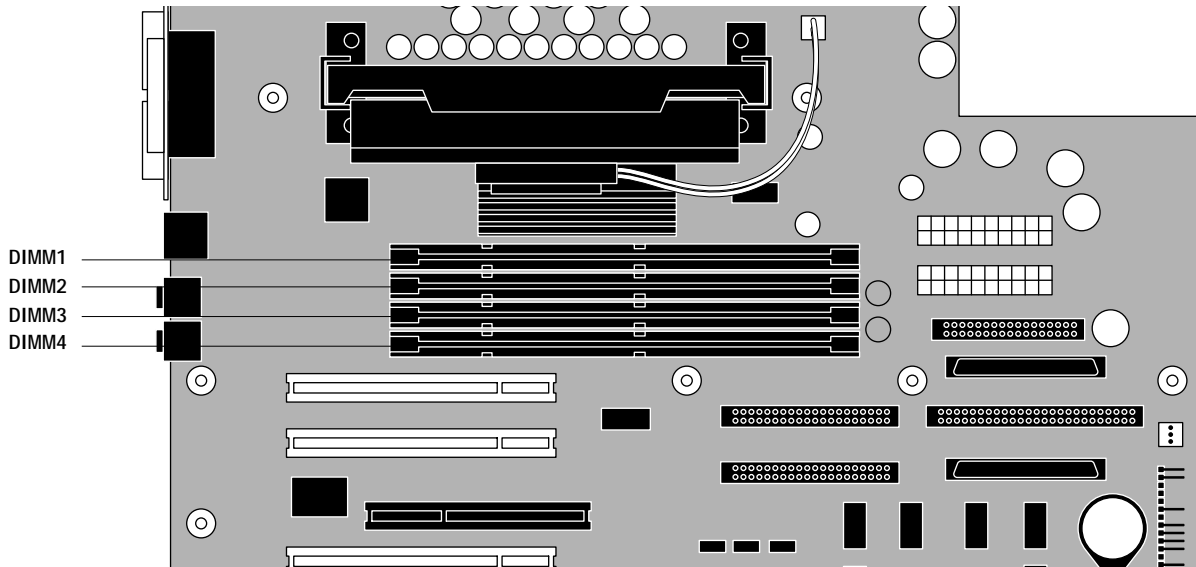

FIGURE 4-19 Motherboard DIMM sockets

4 Motherboard

TO REPLACE A DIMM

1. To release a DIMM, push outward on the levers on each side of the DIMM. (See Figure 4-20.)

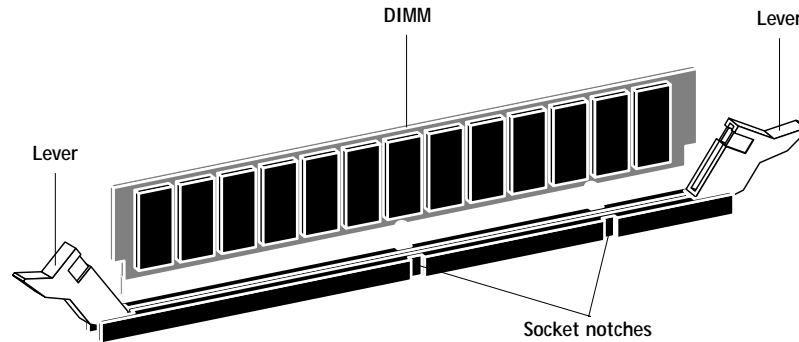

FIGURE 4-20 Releasing a DIMM

2. Slide the DIMM straight out of the socket.
3. To replace a DIMM, slide it straight into the socket and close the levers on each side to lock it into place.

Make sure that the levers close securely around the ends of the DIMM and that each DIMM is fully seated in its socket.

NOTE: DIMMs fit the socket only one way. The two notches on the bottom of each DIMM should line up with the notches in the socket.

4. Reassemble the E-800A and verify its functionality (see "Restoring E-800A functionality after service" on page 4-11).

4

Service Procedures

Motherboard CPU

The motherboard has sockets for two CPUs (CPU1 and CPU2). In the default configuration one Intel Pentium III 500MHz CPU is installed in the socket labeled CPU1.

TO REMOVE THE CPU

1. Remove the CPU fan cable from the connector labeled FAN1 on the motherboard.
2. Remove the clip on top of the CPU assembly that secures the CPU to the side braces.
To remove the top clip, push the latch in towards the CPU on one side and then the other until you hear a click. Once you hear a click the latches are released and you can remove the top clip.
3. Push in on the tabs at the edges of the side braces and gently remove the CPU from its socket.

If you have problems removing the CPU, try removing the screws that secure the side braces to the motherboard.

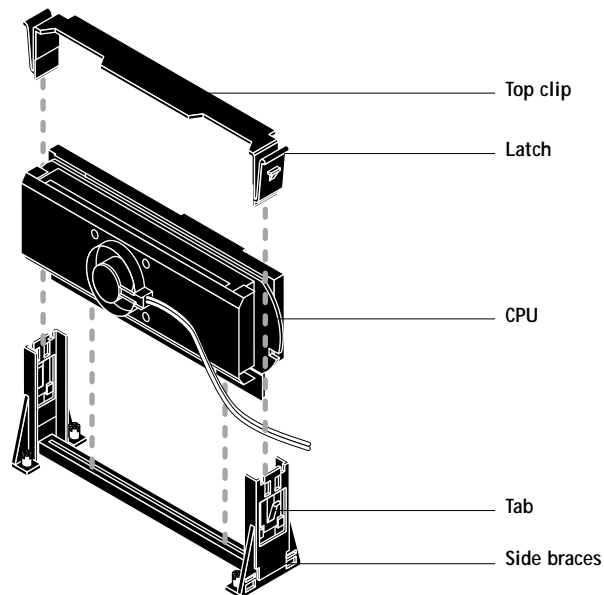

FIGURE 4-21 Replacing the CPU

4

Motherboard

TO REPLACE THE CPU

If you are installing an additional CPU, you will also need to replace the BIOS chip on the motherboard (see “BIOS chip” on page 4-34).

1. Position the CPU so that the fan vent is pointing down in the direction of the power supply. If you removed the side braces you will need to replace them.
2. Slide the CPU into the socket labeled CPU1 on the motherboard and push down on the assembly until you hear it click into place.

If you are inserting a second CPU, install it in the socket labeled CPU2 on the motherboard.

3. Insert the top clip into each side of the braces to secure the CPU. The top clip should be positioned as shown in Figure 4-21 on page 4-32.
4. Connect the CPU fan cable to connector FAN1 on the motherboard.
Use connector FAN2 if a second CPU is being installed.
5. Reassemble the E-800A and verify its functionality (see “Restoring E-800A functionality after service” on page 4-11).

4 Service Procedures

BIOS chip

The BIOS chip is located in socket U67 on the motherboard. The BIOS chip contains boot information, such as the startup diagnostics that the E-800A uses when you power on the system.

NOTE: Factory settings for CMOS are loaded into the BIOS chip each time the E-800A is rebooted.

TO REPLACE THE BIOS CHIP

1. Locate the BIOS chip on the motherboard.
2. Using a PROM extractor, remove the BIOS chip and socket mount from the motherboard.
3. To replace the BIOS chip, insert it into the socket so that the notch in the chip is aligned with the notch in the socket.

Also, make sure to align the pins on the socket mount with the holes in the socket. If you notice any bent pins, straighten them gently with a pair of needlenose pliers.

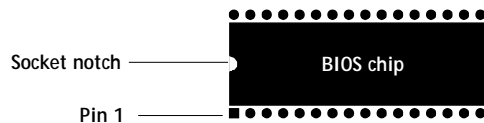

FIGURE 4-22 Diagram of BIOS chip socket

4. Reassemble the E-800A and verify its functionality (see "Restoring E-800A functionality after service" on page 4-11).

4 Motherboard

Motherboard battery

The battery on the motherboard is located at BT1.

TO REPLACE THE MOTHERBOARD BATTERY

1. Locate the battery on the motherboard (see Figure 4-17 on page 4-24.)
2. Carefully push the clip away from the battery until it pops out of the socket.

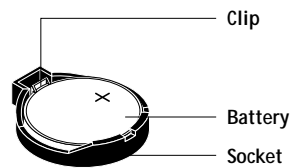

FIGURE 4-23 Motherboard battery

3. Slide the battery out of its socket.
4. To insert a new battery, slide the battery into the socket under the clips with the positive (+) side facing up.
5. Press the battery down into the socket until it snaps into place.
Make sure the battery is securely installed in the socket.
6. Reassemble the E-800A and verify its functionality (see "Restoring E-800A functionality after service" on page 4-11).
7. Configure the time and date in Setup.

4

Service Procedures

Motherboard jumpers and switches

The E-800A motherboard ships with jumpers installed on pins 1 and 2 of jumper area JP9 and a jumper installed on J21. All other jumper areas do not have jumpers installed. Switch S4 on the motherboard is not used; Pentium III CPUs have the clock speed preset and therefore switch S4 is ignored.

Fans

Inside the E-800A, a front fan and a back panel fan run continuously when the system is running. You should hear the fans start as soon as you power on the E-800A. If you do not hear the fans, the most likely problem is a faulty power connection (see “To check board and cable connections” on page 4-8).

The following procedures describe how to remove and replace the front fan and the back panel fan.

Front fan

The front fan circulates air inside the E-800A in order to cool highly integrated circuits within the system.

TO REMOVE THE FRONT FAN

1. Power off and open the E-800A as described on page 4-3 and page 4-4.
2. Unplug the 3-pin fan connector from motherboard connector FAN5.
3. Remove and set aside the two screws that attach the board guide to the tray.
4. Unhook and remove the board guide (with front fan attached) from the tray.
5. Remove and set aside the four screws (and washers, if present) that attach the front fan to the board guide.

4 Fans

TO REPLACE THE FRONT FAN

1. Position the fan on the board guide.

An arrow on the side of the fan indicates the airflow direction. Make sure the fan is positioned so that the arrow points inside the E-800A and so that the fan cable can reach motherboard connector FAN5.

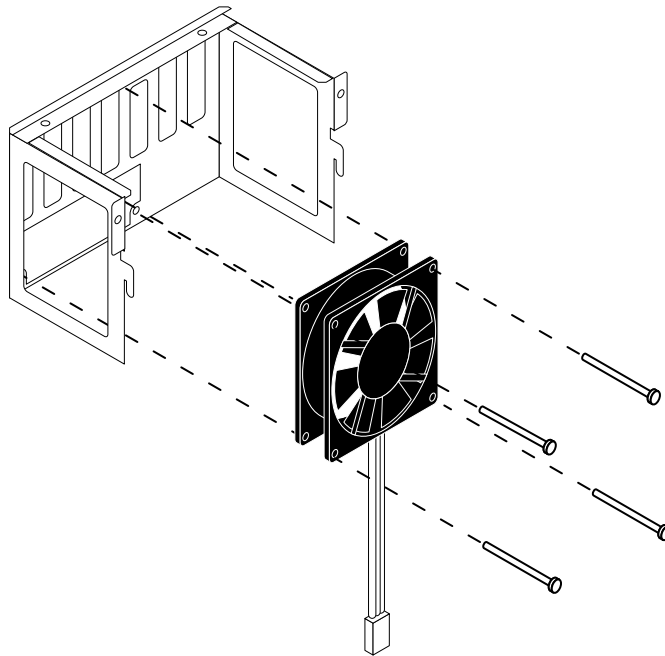

FIGURE 4-24 Removing the front fan

2. Install the fan on the board guide using the four screws (and washers, if present) that you removed earlier.
3. Hook the board guide (with front fan attached) into the tray.
4. Attach the board guide to the tray using the two screws you removed earlier.
5. Plug the 3-pin fan connector into the motherboard connector FAN5.
6. Reassemble the E-800A and verify functionality (see the steps described on page 4-11).

4

Service Procedures

Back panel fan

The back panel fan cools the system by blowing air from inside the system out of the back of the E-800A.

TO REMOVE THE BACK PANEL FAN

1. Power off and open the E-800A, as described in "To shut down the E-800A" on page 4-3 and "To open the E-800A" on page 4-4.
2. Unplug the 3-pin fan connector from motherboard connector FAN3.
3. Pull on one edge of the fan to release it from the mounting bracket.

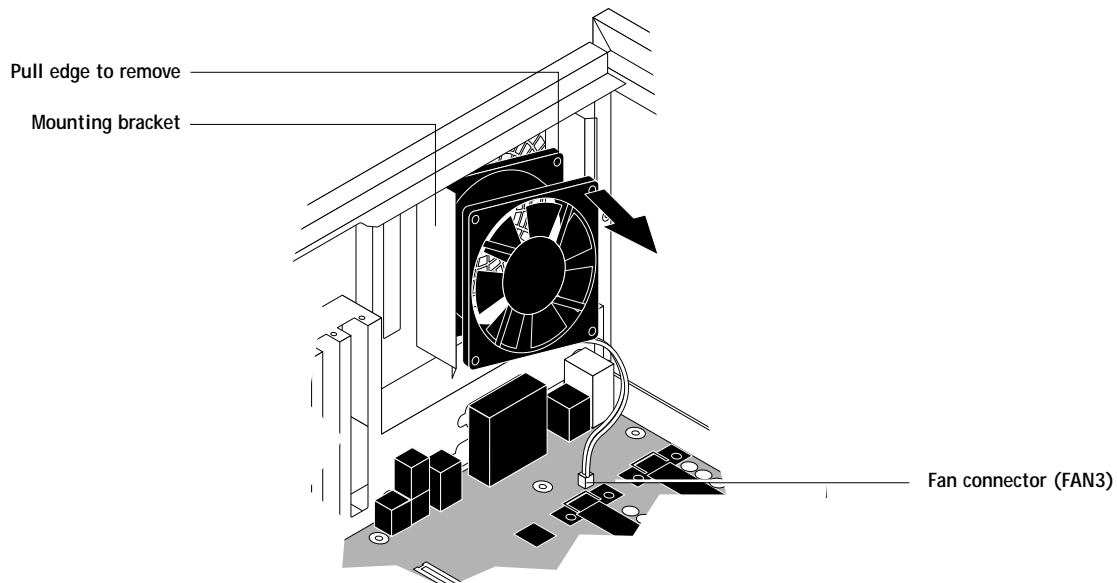

FIGURE 4-25 Removing the fan

4. Remove the fan from the tray.

4

Fans

TO REPLACE THE BACK PANEL FAN

1. Angle one edge of the fan into the mounting bracket on the back panel of the E-800A and snap the fan into the clips on the bracket (see Figure 4-25 on page 4-38).

An arrow on the side of the fan indicates the airflow direction. Make sure the fan is positioned so that the arrow is at the top of the tray and points out toward the back panel.

2. Plug the 3-pin fan connector into the motherboard connector labeled FAN3. See Figure 4-25 on page 4-38.
3. Reassemble the E-800A and verify functionality (see the steps described in “Restoring E-800A functionality after service” on page 4-11).
4. Check the fan vent on the E-800A back panel to make sure air is coming out the back. If the air is not coming out the back, the fan is oriented incorrectly.

4

Service Procedures

Power supply

The fan-cooled 275 watt power supply used in the E-800A has an automatic input voltage selection circuit. The input voltages are 90-137VAC and 180-265VAC.

Checking voltages





You can check power supply functionality using a multimeter at the following locations on the power supply:

- Connector that supplies power to the motherboard
- Connector that supplies power to the HDD
- Connector that supplies power to the CD-ROM drive
- Connector that supplies power to the ZIP drive

4 Power supply

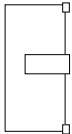
Test voltages on the connectors of the power supply cables, not on the board or component connectors. The following table describes the E-800A power connectors.

TABLE 4-1 E-800A power connectors

Connector	Pins	Color	Voltage
 20-pin Motherboard	1, 2, 11	Green	3.3V
	3, 5, 7, 13, 15, 16, 17	Black	GND
	18	White	-5V
	4, 6, 19, 20	Red	+5V
	10	Yellow	+12V
	12	Blue	-12V
	14	--	not connected
	8	--	Supply Power ok
	9	Red	+5VSB
	 4-pin HDD	1	Yellow
2		Black	common
3		Black	common
4		Red	+5V
 4-pin CD-ROM drive	1	Yellow	+12V
	2	Black	common
	3	Black	common
	4	Red	+5V
 4-pin ZIP drive	1	Yellow	+12V
	2	Black	common
	3	Black	common
	4	Red	+5V

4

Service Procedures

Removing and replacing the power supply

This section describes how to remove and replace the power supply.

TO REMOVE THE POWER SUPPLY

1. Power off and open the E-800A as described in "To shut down the E-800A" on page 4-3 and "To open the E-800A" on page 4-4.
2. Disconnect the 20-pin power cable at connector J18 on the motherboard.
3. Disconnect the 4-pin power cable to the HDD.
4. Disconnect the 4-pin power cable connected to the ZIP drive.
5. Disconnect the 4-pin power cable connected to the CD-ROM drive.
6. Remove the four screws on the back panel of the E-800A that attach the power supply to the tray.
Set the screws aside so they can be replaced later.
7. Gently lift the power supply out of the tray.

TO REPLACE THE POWER SUPPLY

1. Place the power supply inside the bottom left corner of the tray.
2. While supporting the power supply, align the mounting holes with the holes on the back of the tray. Secure the power supply from the outside with four screws.
3. Connect the 20-pin power cable to the motherboard power connector (J18).
4. Connect the 4-pin power cable to the HDD.
5. Connect the 4-pin power cable to the power connector on the ZIP drive.
6. Connect the 4-pin power cable to the power connector on the CD-ROM drive.
7. Make sure all power connectors are properly aligned.
8. Reassemble the E-800A and verify its functionality (see "Restoring E-800A functionality after service" on page 4-11).
If you cut any other tie wraps, make sure you replace them.

4

Hard disk drive

Hard disk drive

The factory-installed HDD (hard disk drive) in the E-800A is formatted and loaded with E-800A system software, including the network drivers and E-800A printer fonts. The HDD is also used to store spooled print jobs. Available space on the HDD is displayed on the Control Panel. In order to remove the HDD, you first need to remove the HDD bracket that holds the HDD.

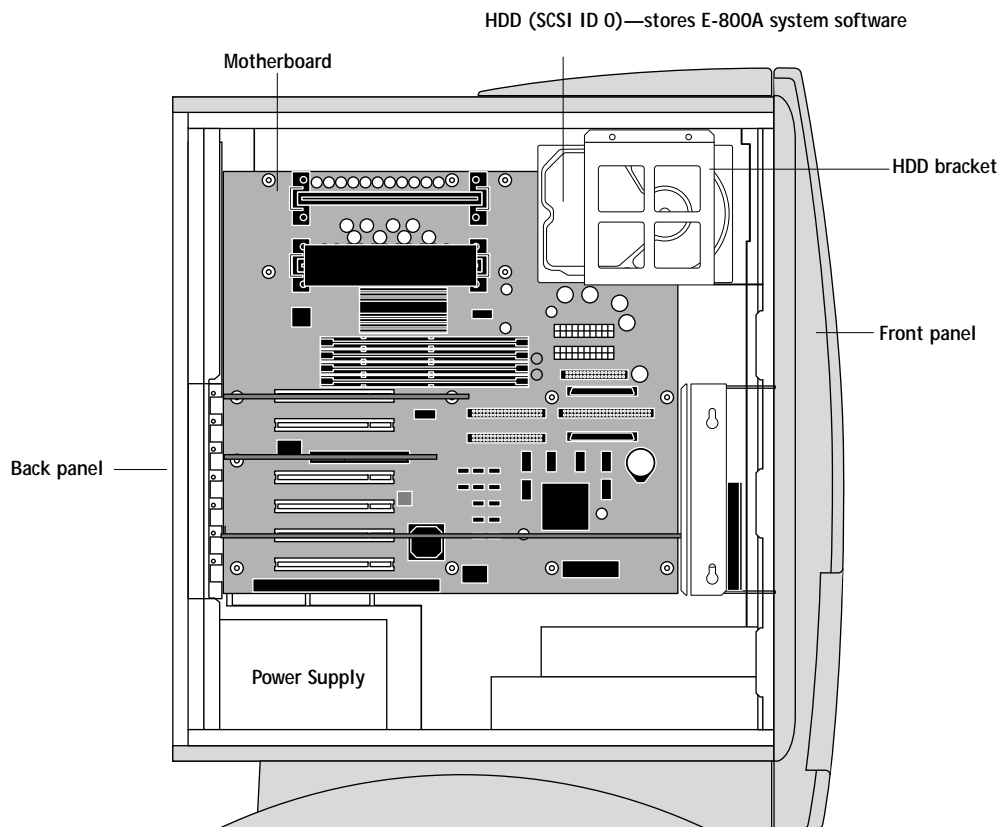

FIGURE 4-26 E-800A HDD (hard disk drive)

E-800A system software and installation instructions are made available to service technicians for field replacement.

4

Service Procedures

If you are replacing the HDD, you will need:

- The appropriate E-800A system software including documentation for the E-800A you are servicing.
- A compatible version of the user software for networked computers that will be printing to the E-800A.

TO REMOVE THE HDD

1. Power off and open the E-800A, as described in "To shut down the E-800A" on page 4-3 and "To open the E-800A" on page 4-4.
2. Remove the SCSI cable connecting the HDD and the motherboard by pulling the connector (not the cable) straight out from the HDD.
3. Disconnect the 4-pin power connector from the HDD.
4. Remove three of the four screws that secure the HDD bracket to the tray (see Figure 4-27.)

Note that the screws are two sizes. The shorter screws must be used to mount the bracket to the front panel and the longer screws must be used to mount the bracket to the top of the tray. Keep each pair of screws together so that you can replace them correctly later.

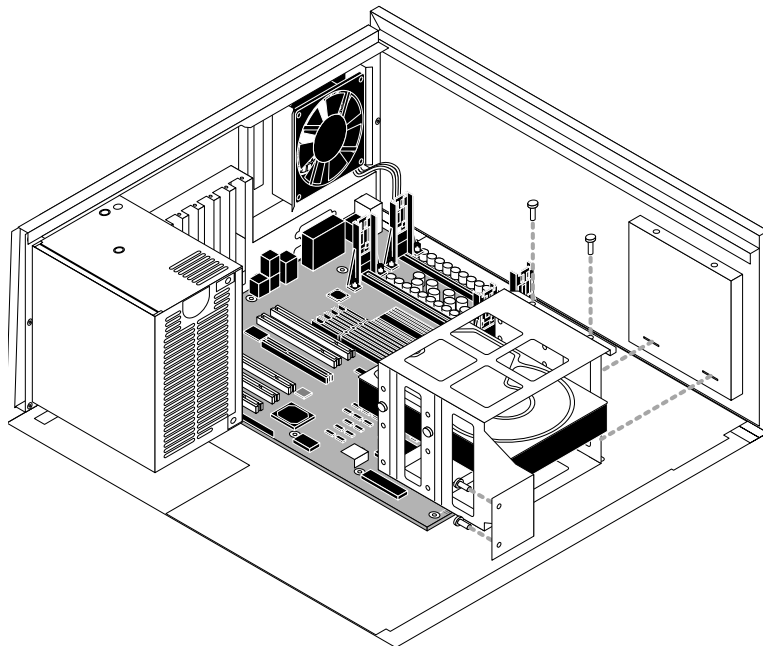

FIGURE 4-27 Removing the HDD and bracket

5. While supporting the HDD bracket, remove the fourth screw.

4

Hard disk drive

6. Gently slide the HDD bracket toward the back panel to unhook it from the tray.

If you are removing the HDD bracket in order to remove the motherboard, you do not need to remove the HDD from the bracket.

7. While supporting the HDD, remove the four screws that fasten the HDD to the bracket.



Do not unscrew the six screws on the rounded side of the HDD. Loosening these HDD screws will break the seal and void the HDD warranty.

Do not touch the drive with magnetic objects (such as magnetic screwdrivers) and avoid placing items such as credit cards and employee ID cards that are sensitive to magnets near the HDD.

8. Remove the HDD from the HDD bracket and place the drive in an antistatic bag.

Replacement hard disk drives are not shipped with any E-800A software pre-installed. After installing the drive, you need to install the appropriate E-800A system software.

TO REPLACE THE HDD

1. If you are installing a new HDD, unpack the drive.

Do not touch the HDD with magnetic objects or place objects sensitive to magnets near the drive.

2. Slide the drive into the HDD bracket so that the HDD screw holes are properly aligned with the holes in the bracket.

The HDD should be positioned as shown in Figure 4-28.

3. Once the HDD is properly aligned in the bracket, replace the screws on each side of the HDD and tighten them. (Make sure you use the same screws you removed earlier.)

If some screws do not thread properly, loosen other screws so that the holes may be aligned more easily.

4. Insert the hooks on the HDD bracket into the slots on the bottom of the tray and slide the bracket toward the front panel to secure it. (See Figure 4-27.)

5. Secure the HDD bracket to the tray using the screws you removed earlier. (Make sure the shorter screws are used to secure the bracket to the front panel.)

6. Attach the 4-pin power supply cable connector to the HDD.

7. Attach the SCSI cable from the motherboard to the HDD SCSI connector.

The connector is keyed to attach only one way.

8. Reassemble the E-800A (see "Restoring E-800A functionality after service" on page 4-11).

9. Re-establish the connections at the back of the E-800A.

4

Service Procedures

10. If you replaced the HDD with a new HDD, install E-800A system software (see "E-800A system software service" on page 4-55).

If a startup error appears on the Control Panel when you power on the E-800A, check the E-800A connections. If a startup error still appears, call your authorized service/support center.

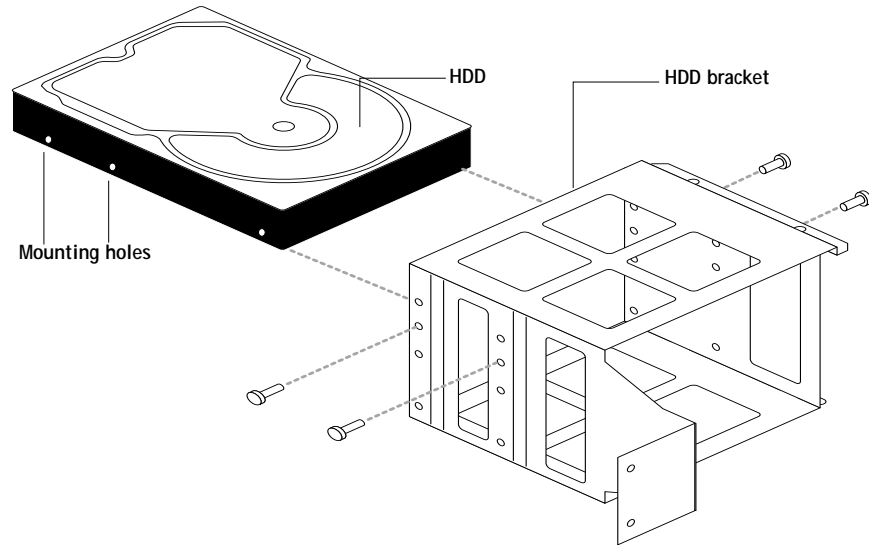

FIGURE 4-28 Replacing the HDD

4 ZIP drive

ZIP drive

The ZIP drive is installed in the tray above the CD-ROM drive and can be used to archive print jobs onto a ZIP disk as described in the *Job Management Guide*.

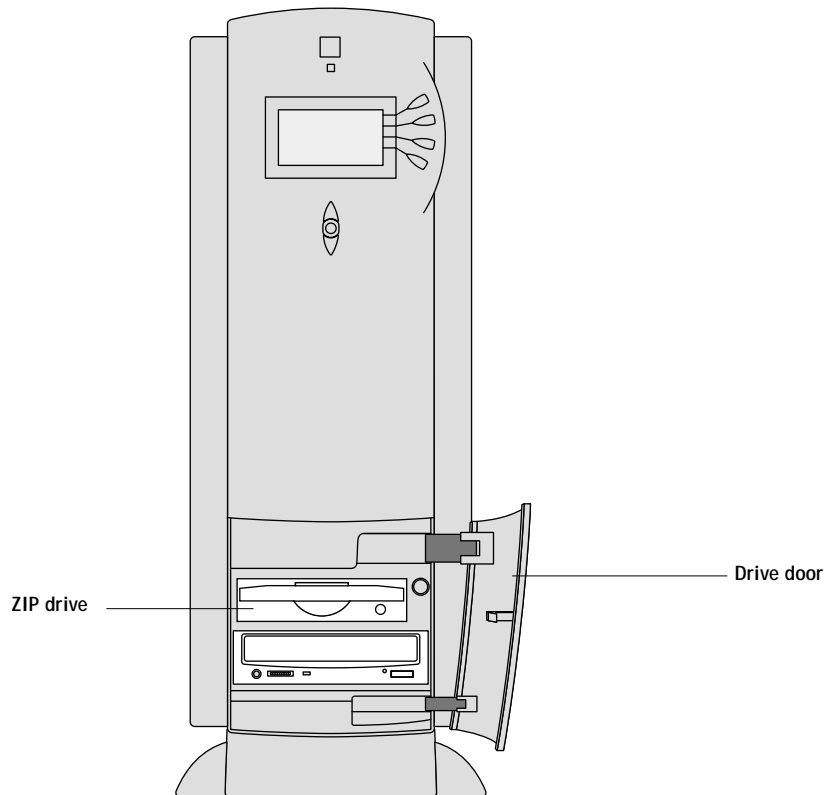

FIGURE 4-29 ZIP drive

NOTE: Jumper pins on the ZIP and CD-ROM drives are used to set the mode (master or slave) for the device on the IDE channel. A label located on the device provides configuration information for setting the mode. The CD-ROM drive is configured as the master and the ZIP drive is configured as the slave. Both drives are configured correctly at the factory and should not be changed.

4

Service Procedures

TO REMOVE THE ZIP DRIVE

1. Power off and open the E-800A, as described in "To shut down the E-800A" on page 4-3 and "To open the E-800A" on page 4-4.
2. Remove the front panel as described in "Accessing front panel components" on page 4-6.
3. Remove any cables connected to the backs of the ZIP and the CD-ROM drives.
In order to remove the ZIP drive you need to remove the bracket that encloses both the ZIP and the CD-ROM drives.
4. Remove the two screws on the front of the tray. These screws secure the bracket to the tray.

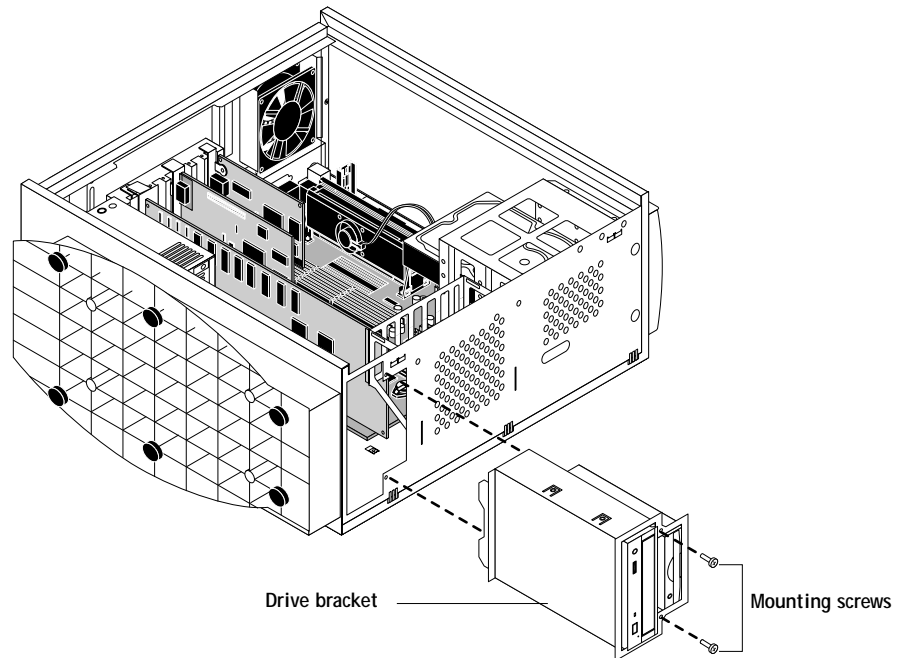

FIGURE 4-30 Removing/replacing the drive bracket

5. Push the drive bracket from inside the tray out through its slot in the front of the tray. Be careful not to damage any components when removing the bracket.

4 ZIP drive

6. Remove the four screws that secure the ZIP drive to the bracket and slide the drive out of the bracket.

Be careful not to damage the EMI gasketing around the edge of the bracket.

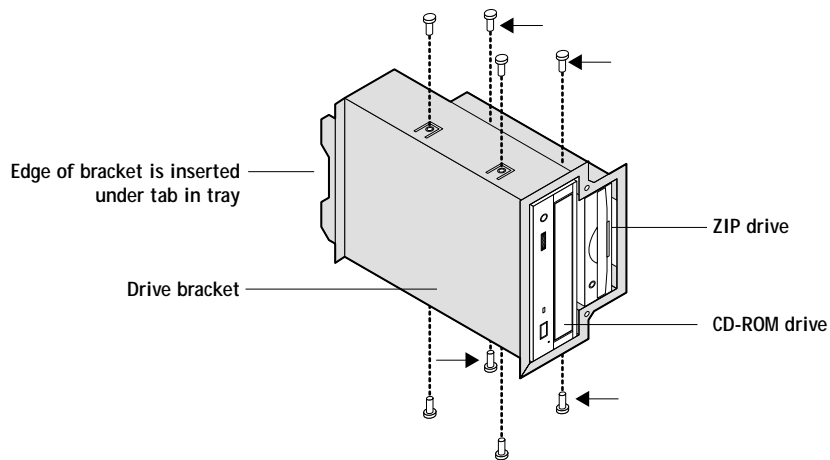

FIGURE 4-31 Replacing the ZIP drive

TO REPLACE THE ZIP DRIVE

1. With the drive bracket removed, slide the replacement ZIP drive into the bracket on top of the CD-ROM drive.
Be careful not to damage the EMI gasketing around the edge of the bracket.
Make sure the IDE setting for the ZIP drive is set to slave.
2. Attach the four screws that secure the ZIP drive to the bracket (see Figure 4-32).
3. Slide the bracket with the drives installed into the drive slot in the front of the tray. The back edge of the drive bracket should fit underneath the tab in the base of the tray.
4. Replace the two screws on the front of the tray that secure the drive bracket to the tray (see Figure 4-30 on page 4-48).
5. Re-establish cable connections to the back of the ZIP and CD-ROM drive and reassemble the E-800A (see "Restoring E-800A functionality after service" on page 4-11).

4 Service Procedures

CD-ROM drive

The CD-ROM drive is installed in the tray below the ZIP drive and is used to install E-800A system software.

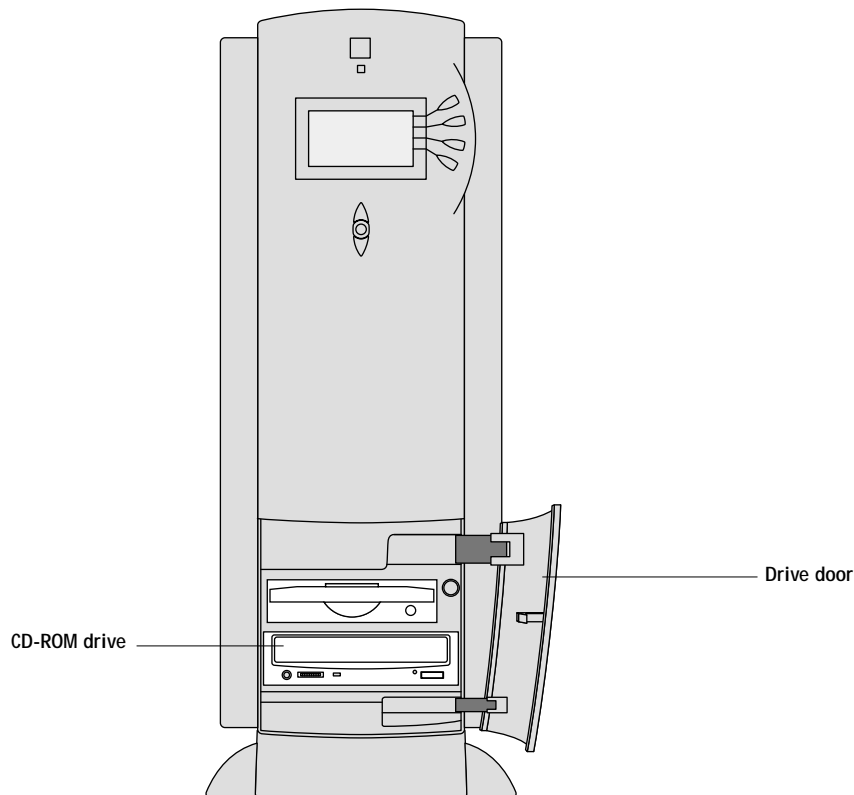

FIGURE 4-32 E-800A CD-ROM drive

NOTE: Jumper pins on the CD-ROM and ZIP drives are used to set the mode (master or slave) for the device on the IDE channel. A label located on the device provides configuration information for setting the mode. The CD-ROM drive is configured as the master and the ZIP drive is configured as the slave. Both drives are configured correctly at the factory and should not be changed.

4

CD-ROM drive

TO REMOVE THE CD-ROM DRIVE

1. Power off and open the E-800A, as described in "To shut down the E-800A" on page 4-3 and "To open the E-800A" on page 4-4.
2. Remove the front panel as described in "Accessing front panel components" on page 4-6.
3. Remove any cables connected to the backs of the ZIP and the CD-ROM drives.
In order to remove the CD-ROM drive you need to remove the bracket that encloses both the ZIP and the CD-ROM drives.
4. Remove the two screws on the front of the tray (see Figure 4-33). These screws secure the bracket to the tray.

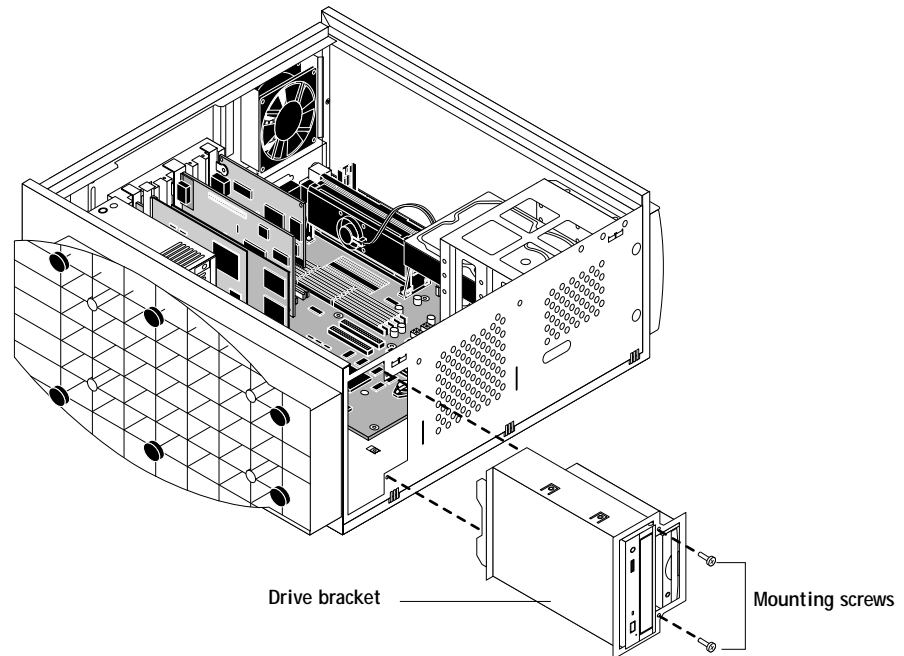

FIGURE 4-33 Removing/replacing the drive bracket

5. Push the drive bracket from inside the tray out through its slot in the front of the tray. Be careful not to damage any components when removing the bracket.

4

Service Procedures

6. Remove the four screws that secure the CD-ROM drive to the bracket and slide the drive out of the bracket
7. Be careful not to damage the EMI gasketing around the edge of the bracket.

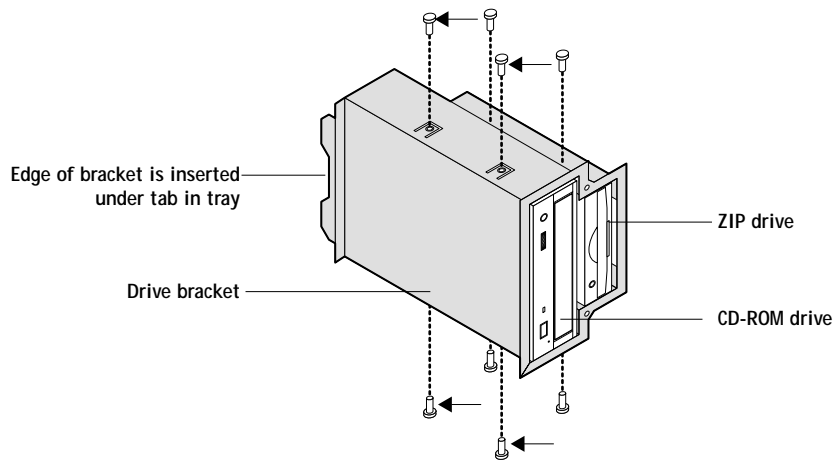

FIGURE 4-34 Replacing the CD-ROM drive

TO REPLACE THE CD-ROM DRIVE

1. With the drive bracket removed, slide the replacement CD-ROM drive into the bracket. Be careful not to damage the EMI gasketing around the edge of the bracket. Make sure the IDE setting for the CD-ROM drive is set to master.
2. Attach the four screws that secure the CD-ROM drive to the bracket (see Figure 4-34).
3. Slide the bracket into the drive slot in the front of the tray. The back edge of the drive bracket should fit underneath the tab in the base of the tray.
4. Replace the two screws on the front of the tray that secure the drive bracket to the tray (see Figure 4-33).
5. Re-establish cable connections to the back of the ZIP and CD-ROM drives and reassemble the E-800A (see "Restoring E-800A functionality after service" on page 4-11).

4 Front panel components

Front panel components

The front panel holds jewels, the user interface board, and buttons. This section describes replacing jewels and buttons on the front panel. For information on replacing the user interface board, see “User interface board” on page 4-20.

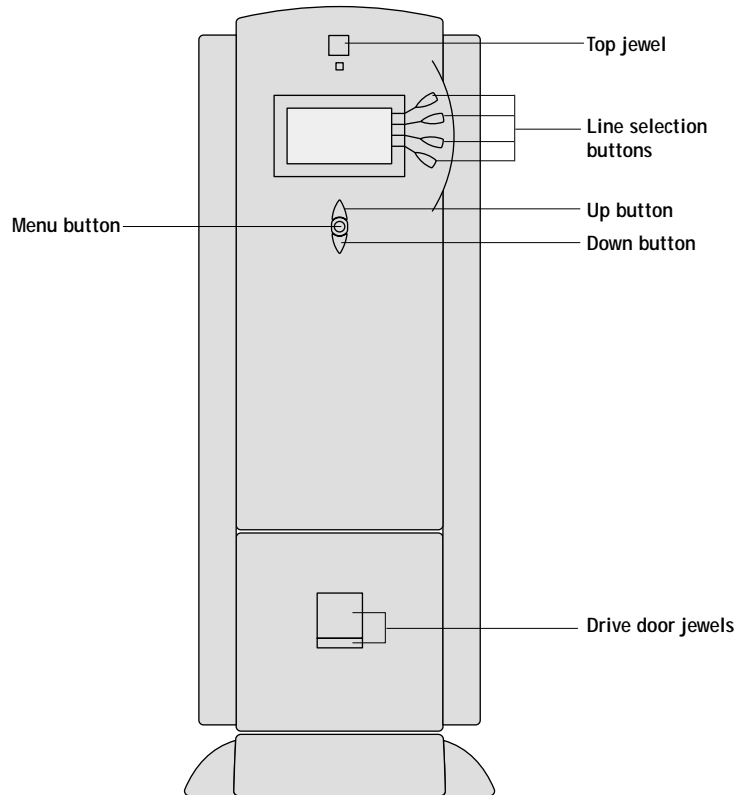

FIGURE 4-35 Front panel jewels and buttons

4

Service Procedures

Jewels

Some upgrades or product modifications may require you to replace a jewel on the front panel of the E-800A. The following procedure describes how to replace a jewel.

TO REPLACE FRONT PANEL JEWELS

1. If you are replacing the top jewel, remove the front panel as described in "To remove the front panel" on page 4-6. To replace the jewels on the drive door, open the drive door.
Now you have access to the tabs on the back side of the jewel.
2. Remove the jewel from the front panel.
Squeeze the tabs on the back side of the jewel while pushing it out of its slot.
3. Insert the new jewel into the empty slot.
Push the jewel into the slot from the front until it snaps into place.
4. If necessary, reassemble the E-800A (see "Restoring E-800A functionality after service" on page 4-11).

Buttons

The Control Panel buttons are located in cutouts in the front panel and are designed to fit only one way. In position, the buttons make contact with the button pads on the front of the user interface board and provide users with manual status/control capability from the Control Panel.

TO REPLACE FRONT PANEL BUTTONS

1. Remove the front panel (see "To remove the front panel" on page 4-6).
2. Remove the user interface board (see "To remove the user interface board" on page 4-21).
3. Place the front panel buttons in the appropriate cutouts; notice the buttons fit only one way in the cutouts.
4. Reassemble the E-800A and verify its functionality (see "Restoring E-800A functionality after service" on page 4-11).

4

E-800A system software service

E-800A system software service

E-800A system software resides on the HDD and is backed up the first time you power on the E-800A from the factory. If necessary, you can retrieve the backup using the Restore Backup function in the Service menu (see page 4-56). This will restore system software to the default configuration.

System software is also provided on a CD. Each language-specific System Software CD can be used to upgrade the system software version on the E-800A or to reinstall the current version of the system software.

This section describes how to retrieve a backup of the system software (see page 4-56) and how to install system software from the CD (see page 4-57).

Keep in mind the following when installing system software from a CD or when restoring the backup system:

- **Job Log**—The list of jobs in the Job Log and any jobs in the queues are deleted. The network administrator can use Fiery Spooler to save a current list of jobs (not the actual jobs) from the Job Log.
- **Fonts**—All fonts installed on the E-800A HDD are deleted. Resident fonts are restored during system software installation. If any additional fonts were downloaded to the E-800A, the network administrator can reinstall the fonts using Fiery Downloader.

To determine which additional fonts were downloaded to the E-800A, print the font list before you install or restore the system software and again after you complete the system software installation. Any fonts *not listed* after installation will need to be reinstalled. See the *Job Management Guide* for more information.
- **Configuration**—When upgrading the system software make sure to print a Configuration page before loading any software (see page 3-8 for instructions). The Setup configuration of the E-800A will be lost during installation of system software.
- **Command WorkStation**—If Command WorkStation software is installed on the E-800A, it will be deleted. After installing or restoring system software, you must reinstall the Command WorkStation. See *Getting Started* for more information.
- **Custom simulations**—Custom simulations and custom outputs saved on the E-800A are deleted when you install or restore system software. Save a copy of any custom simulations before installing software so they can be restored later. See the *Color Guide* for more information.
- **Compatibility**—When upgrading the system software make sure the latest user software is installed onto all computers that print to the E-800A. Using incompatible versions of the system and user software may result in system problems.

4

Service Procedures

Retrieving backup system software

The restore backup function can be used for troubleshooting system problems. When you restore system software the E-800A configuration is returned to default settings.

NOTE: Do not interrupt the system while the restore backup function is in progress. If this occurs you will need to reinstall system software from the CD.

TO RESTORE BACKUP SYSTEM SOFTWARE

1. If you have not done so already, print the following from the Functions menu (if possible):
 - Configuration page —records the customer's current Setup configuration. The Setup configuration will be reset to the default configuration when backup system software is restored.
 - Font List— the E-800A Font List details what fonts are resident on the E-800A HDD. Along with the fonts provided, the customer may have installed additional fonts that will be deleted when the backup system software is restored.
2. Access the Functions menu and then select Reboot System from the Shutdown menu (shown below).

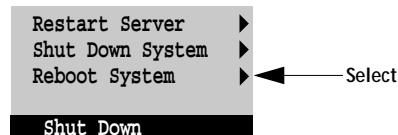

3. When the diagnostics begin, press the fourth line selection button to access the Service menu.

If you do not press the fourth line selection button before the end of the diagnostics, the E-800A continues startup and you must restart the system and try again.

4. Select Restore Backup from the Service menu.

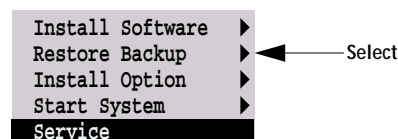

4

E-800A system software service

5. When the following screen is displayed, make sure “Yes” is displayed and then select OK. The restore backup process will begin immediately.

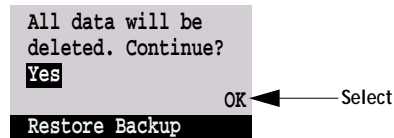

Wait while the E-800A Control Panel displays screens that indicate that the software is being restored. After the system software is restored, the E-800A will run diagnostics. Once the system is restored, the Idle screen is displayed.

6. Configure Setup using the Configuration page you printed earlier.
Bypass settings not included on the Configuration page if it is more appropriate for the network administrator to set them. See the *Configuration Guide* for more information.
7. Reinstall fonts, Command WorkStation software, or custom simulations that may have been deleted due to system software restoration.

Installing system software from a CD

The E-800A System Software CD includes the system software and fonts. Use the System Software CD when:

- You replace the E-800A HDD
- You upgrade to a more recent version of the system software
- Restore Backup fails
- You change languages

TO INSTALL E-800A SYSTEM SOFTWARE

1. If you have not done so already, print the following from the Functions menu (if possible):
 - Configuration page —records the customer’s current Setup configuration. The Setup configuration will be reset to the default configuration when system software is installed.
 - Font List— the Font List details what fonts are resident on the E-800A HDD. Along with the fonts provided, the customer may have installed additional fonts that will be deleted when system software is installed.

4 Service Procedures

2. Access the Functions menu and then select Reboot System from the Shutdown menu (shown below).

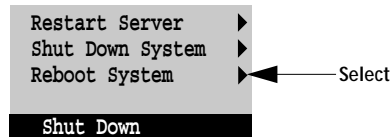

3. When the diagnostics begin, press the fourth line selection button to access the Service menu.

If you do not press the fourth line selection button before the end of the diagnostics, the E-800A continues startup and you must restart the system and try again.

4. Select Install Software from the Service menu.

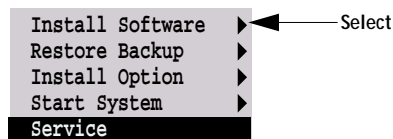

5. At the following screen, press the eject button on the CD-ROM drive and insert the language-specific System Software CD.

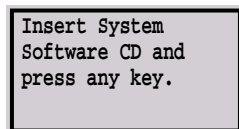

If an error message appears, verify that the correct System Software CD is inserted.

6. When the following screen is displayed, make sure "Yes" is displayed and then select OK. The installation process will begin immediately.

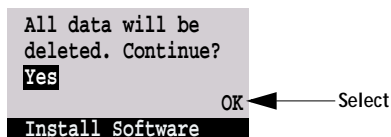

Wait while the E-800A Control Panel displays screens that indicate that the software is being installed.

4

E-800A system software service

7. At the message "To complete installation, remove CD and recycle power," remove the System Software CD and power off and on the system using the power switch on the back panel.

After the system software is installed, the E-800A will initialize the system and will also run diagnostics and create a system backup.

8. Configure Setup using the Configuration page you printed earlier.

Bypass settings not included on the Configuration page if it is more appropriate for the network administrator to set them. See the *Configuration Guide* for more information.

9. Reinstall fonts, Command WorkStation software, or custom simulations that may have been deleted due to system software installation.

5

The troubleshooting process

Chapter 5: Troubleshooting

This chapter identifies the source of common problems that may occur with the E-800A and suggests ways of correcting them.

The troubleshooting process

The troubleshooting process is designed to eliminate the most obvious causes of failure before progressing to more complex solutions. “Where problems occur” on page 5-2, gives an overview of the E-800A system and indicates areas most likely to require troubleshooting.

- Problems with initial installation

If the E-800A fails to complete its initial startup and reach the Idle (ready to print) screen, the most likely cause is a loose cable or board connection. See “Accessing E-800A internal components” on page 4-3 for instructions on opening the E-800A, and “Checking E-800A internal connections” on page 4-8 for descriptions of E-800A parts and connections.

If a loose part or cable is not the cause of the problem, see “Checking the E-800A as a stand-alone unit” on page 5-8, and “Checking the entire E-800A system” on page 5-18.

- Try a phone check before you go to the customer site

“Before you go to the customer site” on page 5-3 suggests areas you should check out before making a call to the customer site. With a phone call you can find out if the problem is a simple operating failure or a failure caused by a network or configuration change. You can ask the customer to check for loose cables on the back of the E-800A and loose connections at a power strip or outlet.

- Check for obvious causes of problems

“Preliminary on-site checkout” on page 5-5 takes you through the initial checkout when you arrive at the customer site. You should check the E-800A internally and externally for the most common problems such as loose cables, connectors, and boards.

- Check the E-800A as a stand-alone unit

“Checking the E-800A as a stand-alone unit” on page 5-8 describes the checks you should perform on the E-800A if the initial checks fail to identify the cause of a problem. With the E-800A disconnected from the copier and the network, test the E-800A as a stand-alone unit.

This section describes possible startup errors and explains how to run and interpret E-800A startup diagnostics.

5 Troubleshooting

- Check the entire E-800A system

“Checking the copier interface” on page 5-18 explains how to print the Test Page from the E-800A. “Checking network connections” on page 5-20 includes guidelines for checking the network connections between the E-800A and the computers or workstations to which it is connected, and also provides information on printing problems.

Where problems occur

The E-800A is a server for color copiers, and it is generally part of a configuration like the one shown below. Problems may occur in one of three areas:

- Inside the E-800A
- In the interface between the E-800A and the copier
- In the interface between the E-800A and the workstations or computers to which it is connected

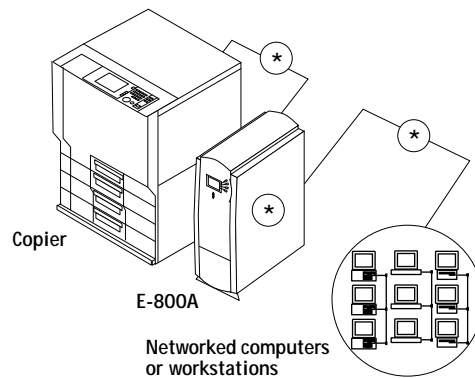

FIGURE 5-1 Troubleshooting the system

This chapter does not attempt to provide troubleshooting information for attached computers such as PCs or Mac OS computers, for color copiers, or for extensive networks. You should refer problems in these areas to the appropriate service departments and network administrators.

5

Before you go to the customer site

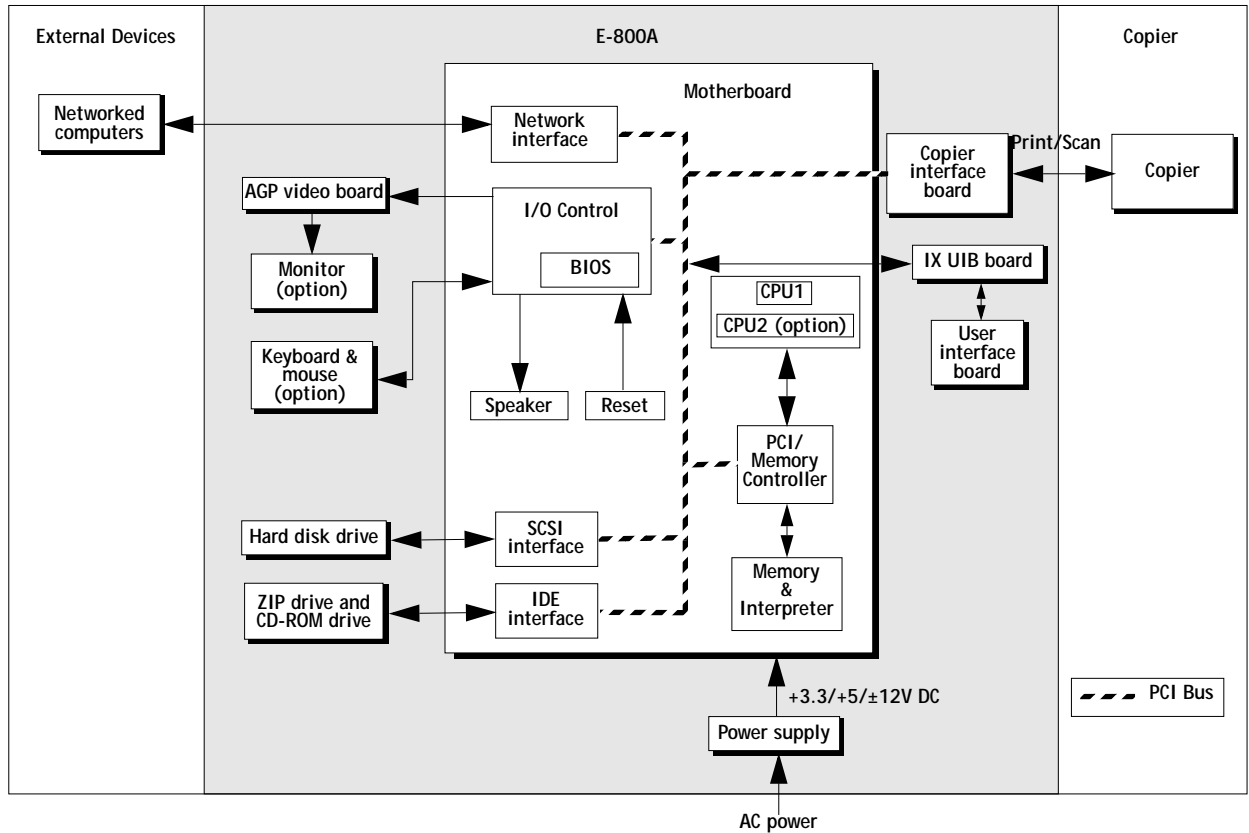

FIGURE 5-2 Functional diagram of a typical configuration

Before you go to the customer site

Before you make a service call to a customer site, talk to the customer on the phone and check out the following items:

1. Does the copier work when it is not connected to the E-800A?

If the copier works but the user cannot print the E-800A Test Page, have the customer check the Control Panel on the E-800A for an error message.

If the E-800A Control Panel reports an error, the customer can check the copier interface cable connection between the E-800A and the copier.

2. Is the failure caused by a simple operating problem?

- Is there a printing problem?
 - Does the E-800A Test Page fail to print?
 - Does the E-800A fail to respond to a print command?

5 Troubleshooting

- Does printing seem to take a long time?
- Is print quality poor?
- Does the E-800A fail to appear in the list of printers?
- Has the customer noted any error messages on the E-800A or the copier screen?

If the answer to any of these questions is yes, refer the customer to a list of E-800A error messages in the *Printing Guide*. If the customer has followed the corrective actions in the *Printing Guide* and still fails to solve the problem, be prepared to make a service call. Keep a log of the failures and messages the customer has observed.

3. Has the customer made any network changes?

If so, request that the customer's network administrator verify the E-800A network requirements. See "Checking network connections" on page 5-20.

4. Has the customer added or removed any equipment that might impact the operation of the E-800A?

If so, obtain a list of the modifications. This should direct you toward possible problem areas. For example, if the HDD has been replaced, system software may need to be re-installed.

5. Is the user having printing problems with a particular image file?

If there are problems with files from particular applications, the user may be more successful using different print settings. The *Color Guide* provides print settings for some popular applications.

If your preliminary phone call fails to clear up the problem, proceed to the second phase, the preliminary on-site checkout.

5

Preliminary on-site checkout

Preliminary on-site checkout

Your goal in the preliminary on-site checkout is to eliminate obvious problems such as loose or missing cables and connectors, or loosely seated printed circuit boards.

Checking interface cables

Before you remove the side and front panel of the E-800A to check internal components make sure that:

- All interface cables to the system are plugged into the proper connectors on the back panel of the E-800A (see Figure 5-3).
- The power cable is plugged into the wall supply.
- The power switch on the back panel of the E-800A is powered on.

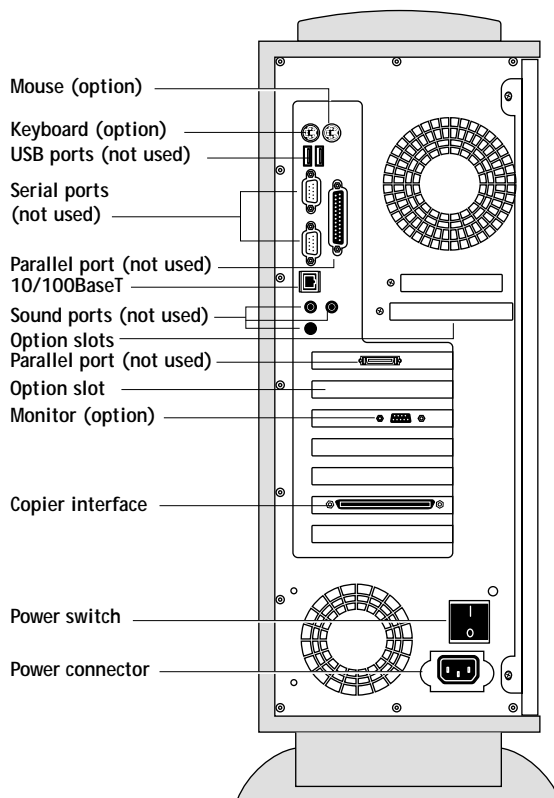

FIGURE 5-3 Back panel of E-800A

If all the connectors are properly in place and the power is on, proceed to the next stage of troubleshooting.

5 Troubleshooting

Checking internal components

To check the internal components you must remove the side and front panel of the E-800A.



Before you remove the side and front panels of the E-800A, be aware of the safety precautions you should take when handling the E-800A, and use ESD precautions when handling printed circuit boards and electronic components. To review the safety precautions, see “Precautions” on page -xiii.

Use the guidelines in Chapter 4 when disassembling, checking, and reassembling the E-800A.

TO CHECK INTERNAL COMPONENTS

1. Power off the E-800A (see “To shut down the E-800A” on page 4-3).
2. Remove the side panel and the front panel as described in “To open the E-800A” on page 4-4 and “To remove the front panel” on page 4-6.
3. Before you touch any components inside the E-800A, attach a grounding strap to your wrist and discharge any static electricity on your body by touching the metal cover of the E-800A.
4. Inspect the inside of the E-800A. For details, see “Checking E-800A internal connections” on page 4-8.
Make sure no foreign materials have been dropped into the tray. Figure 5-4 on page 5-7 shows an exploded view of the system components.
 - Look for obviously loose boards and reseat each board securely in its connector on the motherboard.
 - Look for cables that are obviously loose. Reseat each connector firmly.
 - Make sure each connector is properly aligned with its mating connector. If the pins are offset from each other, the board affected will not function properly.
5. Reassemble the E-800A and verify functionality (see “Restoring E-800A functionality after service” on page 4-11).

5 Preliminary on-site checkout

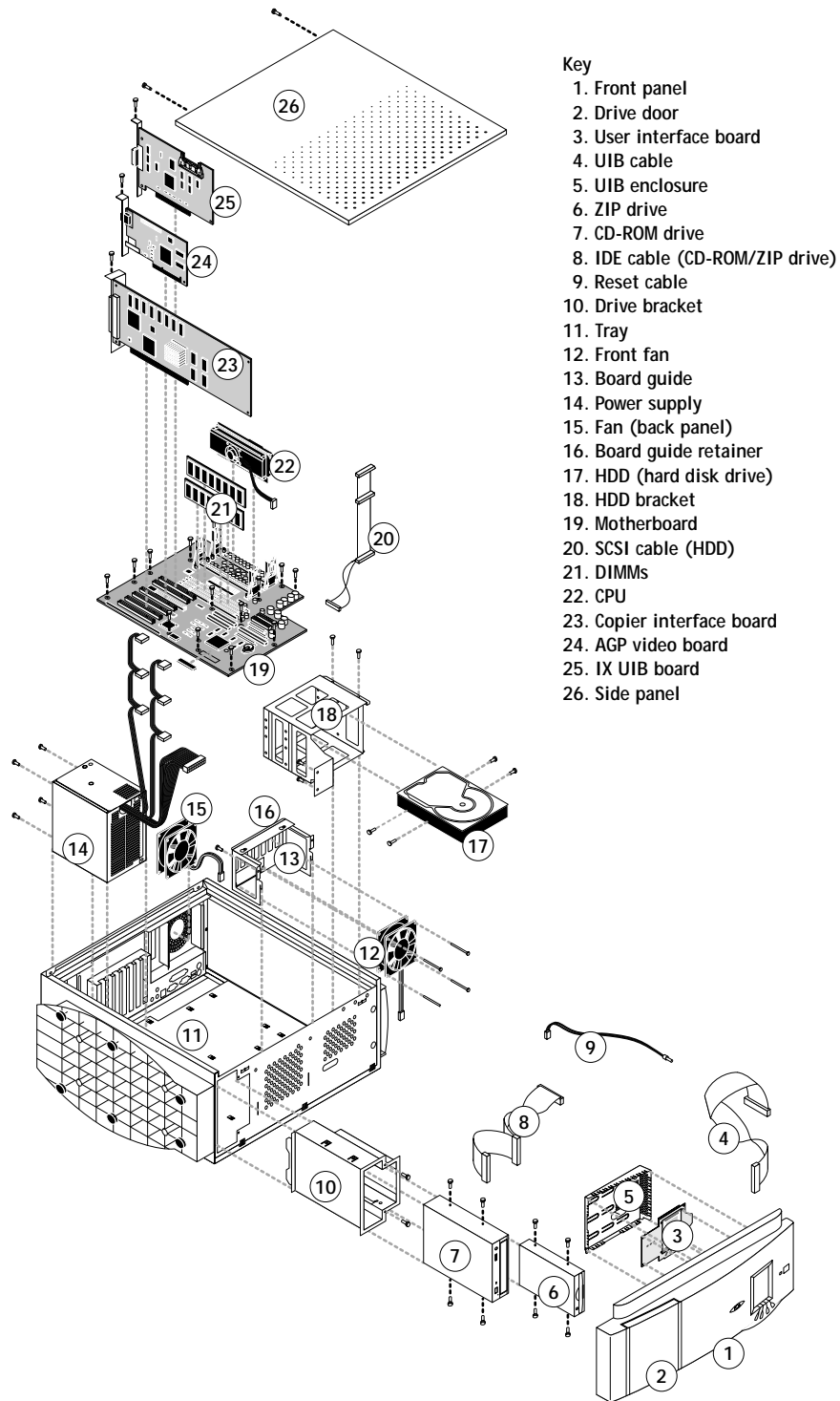

FIGURE 5-4 Exploded view of E-800A components

5

Troubleshooting

Checking the E-800A as a stand-alone unit

To test the E-800A as a stand-alone unit:

- Disconnect the E-800A from the copier and from the network
- Check for possible startup problems
- Check Setup (See the *Configuration Guide* for details)

TO ISOLATE THE E-800A

1. Isolate the E-800A from the copier and from the network by disconnecting the following cables from their connectors on the back panel of the E-800A:
 - Network connector
 - Copier interface connector
2. Make sure the power cable to the E-800A is still in place.
3. Power on the E-800A and allow the startup diagnostics to run.

5

Checking the E-800A as a stand-alone unit

Errors and beep codes during startup diagnostics

When you turn on the E-800A or reboot, the system performs diagnostic tests that check the motherboard. While the diagnostic tests are running, the name of each test is displayed on the Control Panel. If an error occurs during the startup diagnostics, the red activity light on the E-800A Control Panel turns on. At the end of the diagnostics, the red activity light remains on and the error appears on the Control Panel.

Pressing and holding the fourth line selection button during the startup diagnostic displays the Service menu. This screen allows you to reinstall system software if required, recover a backup of the system, and install options (such as the Advanced Controller Interface option).

If the system cannot display the startup diagnostic screen, the E-800A will indicate an error with beep codes and a flashing red activity light.

NOTE: During startup, the diagnostics check the activity light to make sure it is functional. The activity light on the E-800A Control Panel flashes red briefly during this time even though no errors have occurred.

When you encounter any of these conditions, power off the E-800A and inspect the inside of the tray for an obviously loose part or cable. Then check the other components as suggested in the following tables. For all service, see “Accessing E-800A internal components” on page 4-3. When you are finished, see “Restoring E-800A functionality after service” on page 4-11.

Table 5-1 lists the possible beep codes, the area on the motherboard reporting the error, and how to correct the error. Table 5-2 lists the possible error messages that may be reported to the Control Panel and the suggested corrective action.

5 Troubleshooting

TABLE 5-1 E-800A beep codes

Beep code	Area reporting the error	Suggested action
5 short beeps—pause—1 long beep 6 short beeps—pause—1 long beep	DIMMs	<ul style="list-style-type: none"> • Make sure all DIMMs installed on the motherboard are Electronics For Imaging approved. • Reseat all DIMMs in their sockets and restart the E-800A in order to run the startup diagnostics. • If the error persists, replace each DIMM one at a time with a good DIMM until you locate the faulty DIMM(s). • If the above does not correct the error, you may need to replace the motherboard.
8 short beeps—pause—1 long beep	CMOS settings	<ul style="list-style-type: none"> • Reboot the E-800A. • If the problem persists, replace the battery on the motherboard. • If the problem still persists, you may need to replace the motherboard. <p>NOTE: If you replace the battery, reset the time and date in Setup after replacing the battery.</p>
9 short beeps—pause—1 long beep 10 short beeps—pause—1 long beep 11 short beeps—pause—1 long beep	DIMMs	<ul style="list-style-type: none"> • Make sure all DIMMs installed on the motherboard are Electronics For Imaging approved. • Reseat all DIMMs in their sockets and restart the E-800A in order to run the startup diagnostics. • If the error persists, replace each DIMM one at a time with a good DIMM until you locate the faulty DIMM(s). • If the above does not correct the error, you may need to replace the motherboard.

NOTE: Some beep codes continue to loop until the E-800A is powered off and the error is corrected.

5

Checking the E-800A as a stand-alone unit

TABLE 5-2 Possible errors during startup diagnostics

Error message	Suggested action
Channel 2 Timer Failed	<ul style="list-style-type: none"> • Check connections to the motherboard.
Interrupt Control 1 Failed	<ul style="list-style-type: none"> • If the problem persists, replace the motherboard.
Interrupt Control 2 Failed	
CMOS Battery Failed	<ul style="list-style-type: none"> • Reboot the E-800A.
CMOS System Options Not Set	<ul style="list-style-type: none"> • If the problem persists, replace the battery on the motherboard.
CMOS Checksum Error	<ul style="list-style-type: none"> • If the problem still persists, you may need to replace the motherboard.
CMOS Configuration Error	NOTE: Reset the time and date in Setup after replacing the battery.
CMOS Memory Size Mismatch	<ul style="list-style-type: none"> • Reboot the E-800A. • If the problem persists, replace the battery on the motherboard. • If the problem still persists, you may need to replace the motherboard. NOTE: Reset the time and date in Setup after replacing the battery.
Cache Memory Error	<ul style="list-style-type: none"> • Replace the motherboard.
Floppy Controller Failed	<ul style="list-style-type: none"> • Check cable connections to the floppy drive and the motherboard.
Floppy Drive Error	<ul style="list-style-type: none"> • If the problem persists, replace the floppy drive. • If the problem still persists, replace the motherboard.
Hard Disk Error	<ul style="list-style-type: none"> • Check cable connections to the HDD and the ZIP drives. • If the problem persists, disconnect the ZIP drive and power on the system. • If the error does not occur with the ZIP drive disconnected, replace the ZIP drive. • If that does not correct the problem, try replacing the HDD. • If the problem still persists, you may need to replace the motherboard.
CDROM Error	<ul style="list-style-type: none"> • Check cable connections to the CD-ROM drive. • If the problem persists, replace the CD-ROM drive. • If the problem still persists, try replacing the motherboard.
CMOS Time Not Set	<ul style="list-style-type: none"> • Reboot the E-800A. • If the problem persists, replace the battery on the motherboard. • If the problem still persists, you may need to replace the motherboard. NOTE: Reset the time and date in Setup after replacing the battery.
Cache Memory Error	<ul style="list-style-type: none"> • Replace the motherboard.
Error xxx At yyy System Halted	<ul style="list-style-type: none"> • This is an unexpected error in the BIOS chip. Record the exact message then report it to your authorized service support center.

Note: xxx and yyy are unpredictable values that will be displayed as 3-digit numbers.

5 Troubleshooting

General E-800A system error conditions

When you startup the E-800A or when you install system software, you may encounter error conditions that are not reported during the startup diagnostics. The following table lists some of these error conditions and suggests corrective action.

TABLE 5-3 General E-800A system error conditions

Symptom	Probable cause	Suggested action
No fan sound and E-800A does not start up.	Power supply cable connector to the motherboard is faulty or disconnected.	<ul style="list-style-type: none"> • Check power connection to the motherboard.
	Power supply has failed.	<ul style="list-style-type: none"> • Replace the power supply.
Buttons do not work on the Control Panel.	Connection to the user interface board is faulty or the user interface board is faulty.	<ul style="list-style-type: none"> • Check connections to the user interface board. • If the problem persists, replace the front panel assembly containing the user interface board.
Nothing appeared on the Control Panel when the E-800A was turned on or the backlighting on the Control Panel is discolored.	Connection to the user interface board is faulty or the user interface board is faulty.	<ul style="list-style-type: none"> • Check the user interface cable connection on the IX UIB board and on the user interface board. • Log in to the E-800A from a remote workstation over the network. If you are able to make the connection, the user interface board may be faulty. • If the problem persists, replace the front panel assembly containing the user interface board.
	Connection to the IX UIB board is loose or faulty.	<ul style="list-style-type: none"> • Check the cable connection to the IX UIB board. • Check the connection between the IX UIB board and the motherboard. • If the problem persists, try replacing the IX UIB board.
	Power supply is faulty.	<ul style="list-style-type: none"> • Check power supply connections. • If the problem persists, replace the power supply.
	CPU connection is loose or the CPU is faulty.	<ul style="list-style-type: none"> • Reseat the CPU. • If the problem persists, replace the CPU. • If the problem still persists, you may need to replace the motherboard.
	BIOS is corrupted.	<ul style="list-style-type: none"> • Reboot the E-800A. • If the problem persists, replace the BIOS chip.
E-800A hangs at the EFI logo when turned on.	E-800A system software is corrupted or not installed on the hard disk drive.	<ul style="list-style-type: none"> • Restore the system software backup using the Restore Backup function from the Service Menu. • If the problem persists, install system software from the CD.

5

Checking the E-800A as a stand-alone unit

TABLE 5-3 General E-800A system error conditions (Continued)

Symptom	Probable cause	Suggested action
Startup diagnostics continue to run.	HDD is not installed properly.	<ul style="list-style-type: none"> • Check cable connections to the HDD. • If the problem persists, you may need to replace the HDD.
Check power & cable appears in the E-800A Control Panel.	Problem with the connection between the E-800A and the copier.	<ul style="list-style-type: none"> • Make sure the copier interface cable is connected to the E-800A and the copier. • Make sure that the copier interface cable connections to the copier and the E-800A are secure. • Make sure the copier is on and ready to print. • Print a Test Page. • If this does not correct the problem, you may need to replace the copier interface cable.
	Copier is not turned on when trying to print.	<ul style="list-style-type: none"> • Power on the copier and print a Test Page.
	Faulty copier interface board.	<ul style="list-style-type: none"> • Run Test I/F board from the Functions menu. • If the diagnostics indicate that the copier interface board is bad, replace the board.
Loading hangs on the Control Panel.	System software is corrupted on the HDD.	<ul style="list-style-type: none"> • Restore the system software backup using the Restore Backup function from the Service Menu. • If the problem persists, install system software from the CD.
	Cable connections to the HDD are loose or faulty.	<ul style="list-style-type: none"> • Check cable connections to the HDD. • If the problem persists, you may need to replace the HDD cable or the HDD.
	AGP video board or copier interface board is not seated properly in the motherboard.	<ul style="list-style-type: none"> • Check cable connections to the back of the E-800A and make sure the AGP video board and copier interface board are seated properly in their connectors on the motherboard. • Reboot the E-800A.

5 Troubleshooting

TABLE 5-3 General E-800A system error conditions (Continued)

Symptom	Probable cause	Suggested action
Cannot find bootable media is displayed on the Control Panel.	The wrong CD was inserted when attempting to install system software.	<ul style="list-style-type: none"> • Check the CD inserted in the CD-ROM drive. • Try using a different System Software CD to install system software. • If the problem persist, check connections to the CD-ROM drive and the HDD. • If the problem still persists, replace the CD-ROM drive.
	Cable connections to the CD-ROM drive is loose or faulty.	<ul style="list-style-type: none"> • Check the power and IDE cable connections to the CD-ROM drive. • Check IDE cable connection to the motherboard. • If the problem persists, you may need to replace the CD-ROM drive.
Configuring Hardware hangs on the Control Panel	CD-ROM power cable is loose or the CD-ROM drive is faulty.	<ul style="list-style-type: none"> • Check power cable connection to the CD-ROM drive. • If that does not correct the problem, you may need to replace the CD-ROM drive.
E-800A does not start up or the Control Panel is blank (you may hear the hard disk drive spin up)	CMOS settings in the BIOS chip have been corrupted or the BIOS chip is faulty.	<ul style="list-style-type: none"> • Replace the BIOS chip on the motherboard.
	CPU overheated or is faulty.	<ul style="list-style-type: none"> • Check CPU fan cable connection to the motherboard. • Make sure the CPU is properly seated in its connector on the motherboard. • If the problem still persists, try replacing the CPU.
System performs slow and hangs periodically.	CPU overheated or is faulty.	<ul style="list-style-type: none"> • Check CPU fan cable connection to the motherboard. • Make sure the CPU is properly seated in its connector on the motherboard. • If the problem still persists, try replacing the CPU.

5

Checking the E-800A as a stand-alone unit

TABLE 5-3 General E-800A system error conditions (Continued)

Symptom	Probable cause	Suggested action
Unable to connect to the network or the green LED on the 10/100BaseT connector is not lit.	Ethernet interface on the E-800A motherboard is faulty or the network is faulty.	<ul style="list-style-type: none"> • If the green LED on the 10/100BaseT connector is not lit on the E-800A back panel, check the cable connection to the back panel and the network. • If the network cable is properly connected to the back of the E-800A, connect a different network cable to the back of the E-800A. • If the problem persists, ask the network administrator to check other devices on the network. • If other devices are not functioning, it could be a problem with the network. • If the rest of the network is functioning properly, replace the motherboard.
ZIP drive is not responding, or it cannot be located, or the busy LED remains lit.	Cable connections to the ZIP drive are loose or faulty or the ZIP drive is faulty.	<ul style="list-style-type: none"> • Check the power and IDE cable connections to the ZIP drive. • Check IDE cable connection to the motherboard. • If the problem persists, you may need to replace the ZIP drive. • If replacing the ZIP drive does not correct the problem, try replacing the motherboard.
If the Token Ring option is installed: Token Ring hardware not found or installed message displayed on the Control Panel.	Faulty network connection.	<p>Make sure:</p> <ul style="list-style-type: none"> • The Token Ring board is correctly installed on the E-800A motherboard. • The Token Ring hardware connections to the back of the E-800A are good (DB-9 connector or the RJ-type). • The port on the MAU or wall drop is good. • Enable Token Ring in Setup is set to Yes. This binds the protocol to the Token Ring board and therefore makes the network connection.
Creating backup hangs on the Control Panel.	<p>Copier interface cable connectors are loose or not properly connected.</p> <hr/> <p>AGP video board or copier interface board is not seated properly in the appropriate motherboard connector.</p>	<ul style="list-style-type: none"> • Check copier interface cable connections at the back of the E-800A and on the copier. • Reboot the E-800A. • Reseat the copier interface board and the AGP video board. • Reboot the E-800A.

5 Troubleshooting

TABLE 5-3 General E-800A system error conditions (Continued)

Symptom	Probable cause	Suggested action
When the E-800A boots, the system loops from Loading System to OK to It is now safe to power off the system.	Copier interface cable connectors are loose or not properly connected.	<ul style="list-style-type: none">• Check copier interface cable connections at the back of the E-800A and on the copier.• Reboot the E-800A.
	AGP video board or copier interface board is not seated properly in the motherboard.	<ul style="list-style-type: none">• Reseat the copier interface board and the AGP video board.• Reboot the E-800A.

5

Checking the E-800A as a stand-alone unit

Copier interface board diagnostics

If you suspect there might be a problem with the copier interface board (for example, the print quality of output is poor), you can run the Test I/F board diagnostics to make sure the copier interface board is installed properly.

TO RUN COPIER INTERFACE BOARD DIAGNOSTICS

1. At the Idle screen, press the menu button once to display the Functions menu.

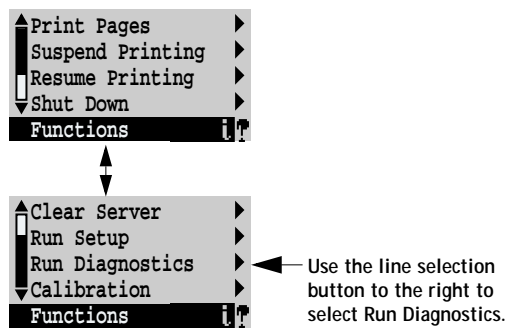

FIGURE 5-5 Run Diagnostics command in the Functions menu

2. Select Run Diagnostics from the Functions menu.
3. At the Diagnostics screen, select Test I/F board.

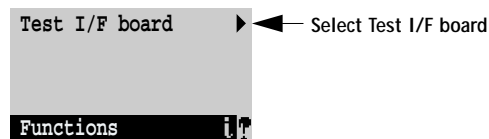

FIGURE 5-6 Test I/F board option

4. If the screen displays the message diags failed, then:
 - Power off the E-800A and open the system.
 - Reseat the copier interface board.
 - Power on the E-800A and run the test again. If the test still fails you may need to replace the copier interface board.
5. Once the Control Panel indicates that the diagnostics passed, press the line selection button next to OK to return to the Functions menu.

5 Troubleshooting

Checking the entire E-800A system

This phase of troubleshooting deals with problems with the entire system. These procedures should be run after verifying that the E-800A functions properly as a stand-alone unit.

Checking the copier interface

After the E-800A starts up successfully as a stand-alone unit, power off the E-800A and connect the copier interface cable (see “Connecting to the copier” on page 3-4). Make sure the E-800A is working properly with the copier before you connect it to the network.

Printing the E-800A Test Page

Once you have connected the E-800A to the copier you should print the Test Page to verify that the interface between the copier and the E-800A is working properly. The Test Page is color file resident on the E-800A HDD. The Test Page is printed to the copier using the settings configured in Setup.

TO PRINT THE TEST PAGE

1. Power on the copier and allow it to warm up.
2. Power on the E-800A from the power switch on the back panel.
Messages appear on the Control Panel as the E-800A runs through its startup diagnostics.
3. Before proceeding, make sure that the copier is not in use. The E-800A Info screen should read Idle.
4. At the Idle screen, press the menu button once. The Functions menu is shown below:

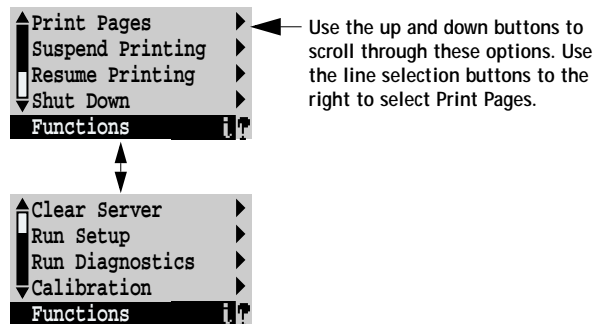

FIGURE 5-7 Functions menu

5

Checking the entire E-800A system

5. Press the line selection button to the right of Print Pages and then select Test Page.

The E-800A sends the Test Page to the copier and displays the RIP and Print status screens so you can monitor the job.

6. Examine the quality of the Test Pages from the copier.

Test Pages confirm that the E-800A print engine is functional and that the connection between the E-800A and the copier is good. The next step is to check the E-800A Test Scan/Print function.

5 Troubleshooting

Checking network connections

After the E-800A is connected to networked computers, printing problems may arise if the network hardware or software is not set up properly or does not match network settings on the E-800A. Problems may also arise when printing from a specific application or printing a particular file.

Most of these problems show up as printing problems, and do not necessarily indicate a E-800A malfunction. The customer's network administrator can eliminate many printing problems without requiring you to make a service call. The network administrator deals with:

- Copier error conditions
- Network connection problems that result in the E-800A not appearing in the printer list on the customer's workstation

NOTE: If the E-800A does not appear in the list of printers on the network, there may be another device on the network with the same Ethernet hardware address.

- Conflicting network settings in Setup and on the customer's workstation
- Printing problems caused by the inappropriate Setup options
- Application-specific printing errors caused by missing or incorrectly placed printer description files

5

Checking the entire E-800A system

Printing to the E-800A

If the user can print the E-800A Test Page, but cannot print a job from a computer on the network, you may have to make a service call. However, first make sure the network administrator has:

- Checked all components of the network including cables, connectors, terminators, network adapter boards, and network drivers
- Activated the network and used it to communicate with other printers
- Checked the corrective actions listed in the *Printing Guide*
- Confirmed that the applicable network settings in Setup (such as AppleTalk zone, IP address, Subnet mask, and Gateway address) match the settings used in the network

When you make a service call, check the back panel of the E-800A to make sure that the appropriate network connections are in place.

Intermittent print quality and color quality problems are difficult to trace. Before you try to troubleshoot print quality problems, copy a color test page to make sure that the copier itself does not need servicing or adjusting.

NOTE: EPS file generation is not completely standardized among applications. Some users may encounter problems while printing certain EPS files.

A

Hardware features

Appendix A: Specifications

This chapter provides an overview of E-800A features.

Hardware features

- Pentium III CPU—500MHz
- Memory—320MB
- An RJ-45 connector for 10Mbps or 100Mbps connectivity over twisted pair cable
- Optional PCI Token Ring board connectivity
- 9.1GB hard disk drive standard
- Built in ZIP drive and CD-ROM drive

Networking and connectivity

- Supports AppleTalk, TCP/IP, and IPX protocols simultaneously
- Supports EtherTalk Phase 2
- RJ-45 connector that supports 10/100BaseT twisted pair network connectivity

User software

A complete description of E-800A user software is provided in *Getting Started*. For optimal E-800A performance, current versions of the user software should be maintained on every network computer that might print to the E-800A.

Safety and emissions compliance

The E-800A has been certified to meet or surpass the following government standards:

Safety approvals

- UL 1950
- CSA 22.2 #950
- EN 60950 (TUV/GS mark)
- CB scheme IEC 950

EMI approvals

- FCC Class B
- VCCI Class B
- EN55022 Class B
- AS/NZS 3548 Class B
- CNS 13438 Class B

A Specifications

Output voltage

The following illustration provides the output voltages for all the interface connectors on the back panel of the E-800A. The output voltages for the extender board are 0V DC on the J1 connector and 0V DC on the J2 connector.

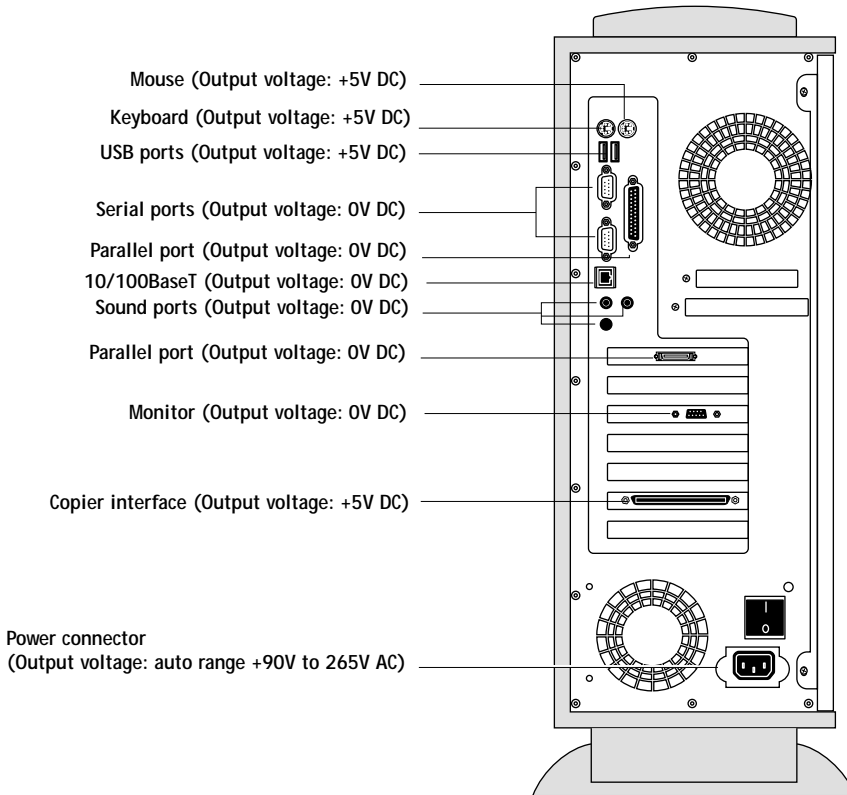
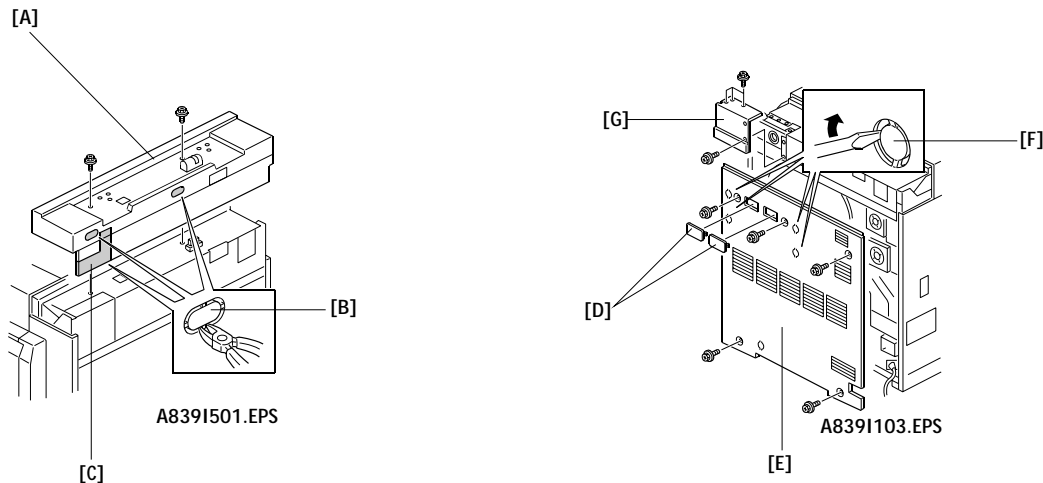

FIGURE A-1 E-800A back panel output voltage

B

Appendix B: Interface Unit and Extender Board Installation Procedures

Use the steps in this appendix to install the interface unit (if it has not been installed) and the extender board on the copier. The interface unit and the extender board must be installed before the E-800A can be connected to the copier.



Unplug the copier power cord before starting the following procedure.

NOTE: Remove the platen cover or ADF if it is installed.

1. Remove the upper rear cover [A] from the copier (2 screws) and cut out the 2 plastic caps [B] and harness inlet plate [C] from the upper rear cover with cutting pliers.
2. Remove the 2 plastic caps [D] from the rear cover [E]; then, remove the 4 metal caps [F] with a blade screwdriver as shown.

NOTE: Place a hand over the metal caps as you pry them out in order to control their trajectory.

3. Remove the rear cover (5 screws) and shield cover [G] (4 screws).

B

Interface Unit and Extender Board Installation Procedures

(The shield cover will not be used any more.)

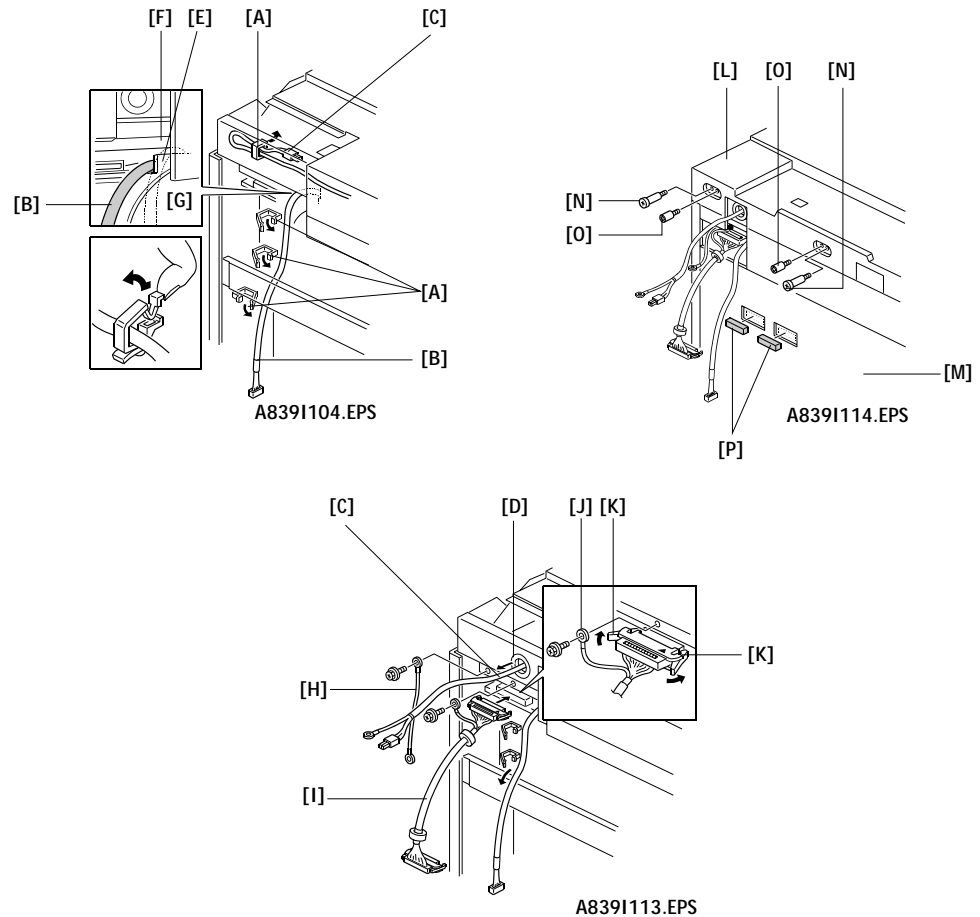

4. Open 4 clamps [A] as shown, pull out the harnesses [B] & [C], and close the clamps. Then, route the harness [C] through the harness bushing [D].

NOTE: Make sure that the harness [B] is routed as shown. If it is routed in between the bracket [E] and stay [F] as shown in dotted line, the harness may touch the flywheel [G].

5. Secure the grounding wire [H] (1 screw). (220 - 240 V version only)
6. Connect the interface harness [I] (connector which has a grounding wire) to the LD control board and secure the grounding wire [J] as shown (1 screw).

NOTE: Insert the connector firmly so that the two lock hooks [K] are engaged as shown.

7. Reinstall the upper rear cover [L] and the rear cover [M] with the three harnesses (3 harnesses and grounding wire on 220 - 240 V version) outside the machine as shown.
8. Secure the hook stud screws [N] and stand-off stud screws [O] (2 each).

B

9. Peel off the seal of two-sided tape and attach the 2 conductive gaskets [P] as shown.

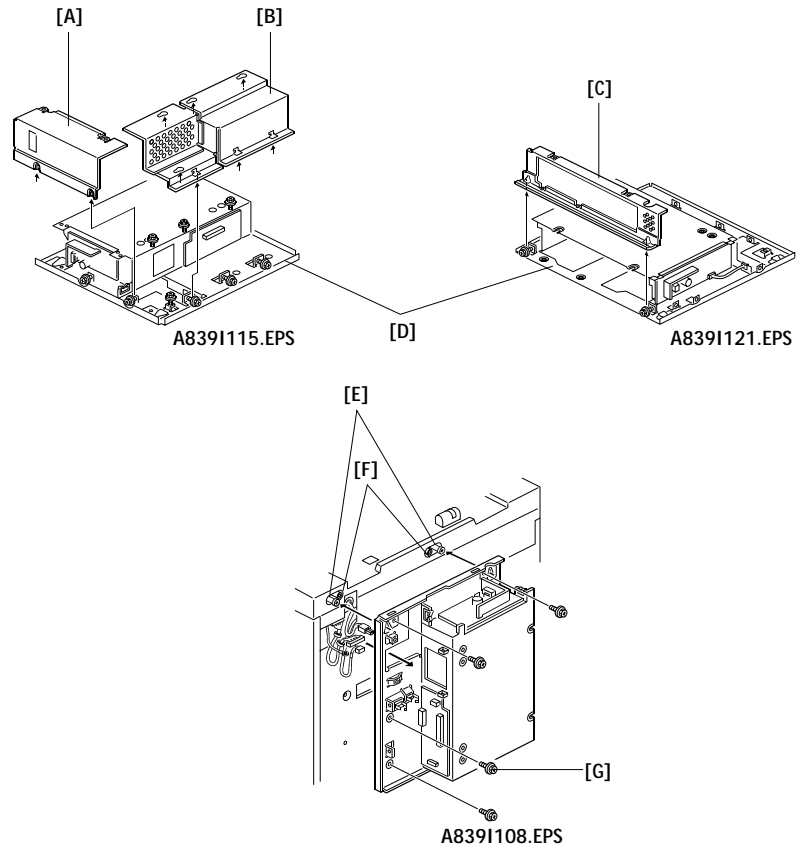

10. Loosen the screws securing the upper shielding cover [A], left shielding cover [B], and right shielding cover [C]; then, remove them from the interface unit [D].
11. Put the 3 harnesses (3 harnesses and grounding wire on 220 - 240 V version) through the cut-out of the interface unit and hook the interface unit on the stud screws [E]. Then, secure the 3 screws (2 screws go into the stand-off stud screws [F]) and 1 grounding screw [G].

B

Interface Unit and Extender Board Installation Procedures

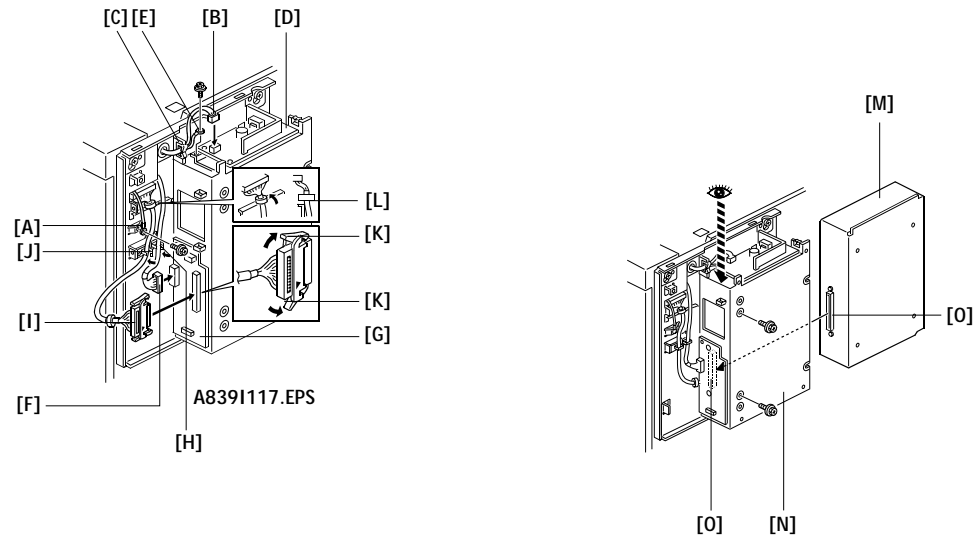

12. Secure the grounding wire [A] (1 screw). (220 ~ 240 V version only)
13. Secure the harness [B] in the clamp [C] and connect the 2P connector on the power supply board [D] of the interface unit. Then, secure the grounding wire [E] as shown (1 screw).
14. Connect the 24P connector [F] on the interface board [G] and secure the harness in the clamp [H].
15. Connect the interface harness [I] to the interface board and secure the harness in the clamp [J].

NOTE: Insert the connector firmly so that the lock hooks [K] are engaged as shown.
Make sure that the ferrite core [L] is placed in the space of the cut out of the interface unit as shown.
16. Insert the extender board [M] in the interface unit [N] (2 screws). (Look down through the top of the interface unit to see the connectors. The extender board needs to be pulled up slightly to engage the connectors smoothly.)

NOTE: Make sure that the connectors [O] are firmly connected.

B

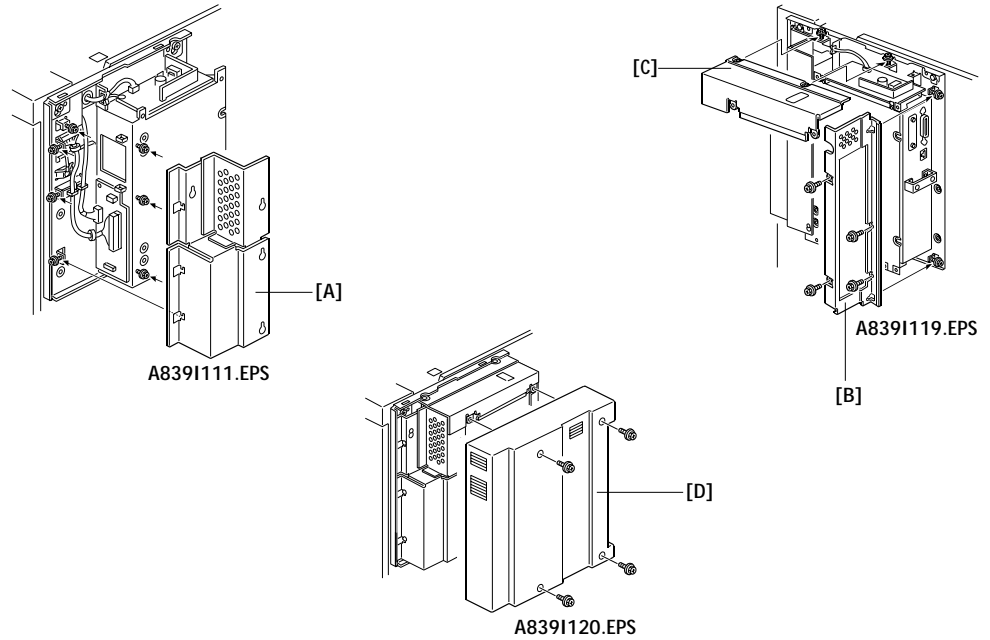

17. Reinstall the left shield cover [A] (7 screws).
18. Reinstall the right shield cover [B] (6 screws) and upper shield cover [C] (2 screws).
19. Install the interface unit cover [D] (4 screws).
20. See Chapter 3 "Connecting the E-800A" for Setup information.

Index

Numerics

10BaseT/100BaseT 2-3, 3-9 to 3-10

A

activity light 2-7, 3-11 to 3-12, 4-20, 5-9

AGP slot 4-5, 4-16

AGP video board 4-8, 4-16
replacement 4-17

Alert screen 3-13 to 3-14

AppleTalk 1-1

B

back panel

connectors on 2-7, 4-5, 5-5
fan on 4-36, 4-38 to 4-39
screws 4-4
slot assignments on 4-5

banks, DIMM 4-30

battery 4-35
motherboard location of 4-24

beep codes 5-10

boards

AGP video 4-16
copier interface 1-2, 4-8, 4-18
IX UIB 4-14
motherboard 4-23
user interface 4-20

boxes, unpacking 2-5

bracket

CD-ROM drive 4-51
ZIP 4-49

buttons

accessing 4-6
down 2-7, 3-11 to 3-12, 4-20
line selection (move left/right) 2-7,
3-11 to 3-12, 4-20
menu 2-7, 3-11 to 3-12, 4-20
reset 2-7
troubleshooting 5-12
up 2-7, 3-11 to 3-12, 4-20

C

cables

category 5 3-10
checking 5-5
copier interface 2-5 to 2-6, 3-4 to 3-5
CPU fan 4-9
fan, back panel 4-9, 4-38
fan, front 4-9, 4-36
IDE 4-9
power 2-5 to 2-6, 3-1, 4-9
reseating 4-8
SCSI 4-9
UIB 4-9, 4-20 to 4-21
UTP 3-10

cancel

printing 3-14
processing 3-14

category 5 cable 3-10

CD-ROM drive 2-7, 4-51 to 4-52
door 2-7

checking

cables 5-5
copier interface 3-6, 5-18
internal components 5-6
network connections 5-20
power & cable message 5-13

checklist for service calls 2-3

Color Charts option 3-16

color management files 1-4

color reference files 1-4

ColorSync color management files 1-4

ColorWise 1-1

components

checking 5-6
exploded view of 4-2, 5-7

Configuration page 3-6, 3-16

Index

connections

- checking 3-6
- copier interface 3-5
- DIMM 4-10
- network 3-9
- power 3-1
- reseating 4-8
- twisted pair (10BaseT/100BaseT) 2-3, 3-9 to 3-10

connectors

- back panel 2-7, 4-5, 5-5
- copier interface 3-4, 4-5, 4-18
- motherboard 4-5, 4-24
- network 3-9
- power 3-1, 4-5
- RJ-45 3-10
- serial ports 4-5
- twisted pair (10BaseT/100BaseT) 3-9, 4-5
- user interface 4-20

Control Panel

- activity light on 2-7, 3-11
- buttons on 2-7, 3-11 to 3-12
- definition *xii*
- display window on 3-11
- jewels 2-7
- Map 3-16
- troubleshooting 5-12
- using the 3-11

copier interface board 4-18

- description 1-2
- motherboard connector 4-8
- replacement 4-19

copier interface cable 2-5, 3-5

copier interface connector 3-5, 4-18

CPU

- fan cable 4-9
- switch setting 4-36

customer site checklist 2-3

D

damage, reporting *xiii*, 2-5

diagnostics

- beep codes 5-10
- copier interface 3-17, 5-18
- Ethernet address 5-20
- Run Diagnostics option 3-17
- startup 5-11
- startup error numbers 5-11

DIMMs

- banks 4-30
- checking motherboard 4-10
- configurations 1-2, 4-30
- removal and replacement 4-31

display window

- cleaning *xiii*
- handling *xiii*
- on user interface board 4-20
- using 3-11

documentation 2-5 to 2-6

door 2-7, 4-47, 4-50

down button 2-7, 3-11 to 3-12, 4-20

Downloader 1-1, 1-3

drive door 4-47, 4-50

drives

- CD-ROM 4-51 to 4-52
- hard disk 4-43
- ZIP 4-48 to 4-49

E

EMI

- approvals A-1
- UIB enclosure 4-21 to 4-22

EPS files 1-3 to 1-4

errors

- activity light 5-9
- check power & cable 5-13
- number 5-11
- reporting with beep codes 5-10
- system 5-12

Index

ESD (electrostatic discharge)

safety precautions *xiv*

Ethernet

address 5-20

exploded view 4-2, 5-7

F

fan

back panel 4-36, 4-38

back panel, cable for 4-38

back panel, replacement of 4-39

front 4-36

front, replacement of 4-37

troubleshooting 5-12

Fiery

Advanced Controller Interface *xii*, 4-16

Downloader 1-1, 1-3 to 1-4

Scan 1-1 to 1-2

Spooler 1-4

WebTools 1-4 to 1-5

fonts 1-1

Adobe Type 1 1-4

screen 1-4

TrueType 1-4

front panel 2-7, 3-11

components 4-6

removing 4-6 to 4-7

replacing 4-7

Functions menu 3-7 to 3-8, 3-13, 3-16, 5-18

Color Charts 3-16

Configuration page 3-16

Control Panel Map 3-16

copier interface board diagnostics 3-17

Job Log 3-16

Print Pages 3-16

Resume Printing 3-16

Run Diagnostics 3-17

Shut Down 3-17

Suspend Printing 3-16

Functions screen 3-15

H

hard disk drive

bracket screws 4-6

description 4-43

removal of 4-44

replacement 4-45

SCSI ID 4-43

HDD 4-43 to 4-45

I

ICM color management files 1-4

icons

Alert 3-14

Functions 3-15

Info 3-15

Network 3-15

Print 3-14

RIP 3-14

Idle screen 3-3

Info screen 3-13, 3-15

installation sequence 2-2

Interface extender board 2-5

initial startup 3-1

IP address *xiii*

IX UIB board 4-14

replacement 4-15

J

J4 4-7

jewels 2-7, 4-6

Job Log

option in Functions menu 3-16

printing 3-16

jumpers on motherboard 4-36

L

LAN (local area network) *xiii*

LED 2-7, 3-11 to 3-12, 4-20, 5-9

line selection buttons 2-7, 3-11 to 3-12, 4-20

Index

M

- media package 2-5 to 2-6
- memory configurations 1-2, 4-30
- menu button 2-7, 3-11 to 3-12, 4-20
- menus
 - Functions 3-7 to 3-8, 3-13, 3-16, 5-18
- motherboard
 - battery 4-24, 4-35
 - completing and verifying installation 4-29
 - connectors 4-5, 4-8, 4-24
 - description 4-23
 - DIMMs 4-10, 4-30 to 4-31
 - illustrated 4-24
 - installation 4-28
 - jumpers 4-36
 - mounting screws 4-24
 - removal 4-25 to 4-27
 - snap top standoffs 4-27 to 4-28
 - switch 4-36
- move left/right buttons 2-7, 3-11 to 3-12, 4-20

N

- NetWise 1-1
- network connections
 - checking 5-20
 - overview 3-9
 - precautions *xiii*
 - twisted pair (10BaseT/100BaseT) 2-3, 3-9 to 3-10
- networks
 - connecting the server to 3-9
 - icon 3-15
 - Novell 1-1
 - supported 1-1 to 1-2, A-1
 - Token Ring 3-9
- Novell networks 1-1

O

- opening the system 4-4
- options installation 3-9

P

- PCI1 4-8, 4-15
- PCI2 4-8
- PCI3 4-8
- PCI4 4-8
- PCI5 4-8, 4-19
- PCI6 4-8
- PDF 1-1, 1-3
- Photoshop
 - plug-ins 1-4
- Portable Document Format 1-1, 1-3
- PostScript
 - screen fonts 1-4
- PostScript 3 1-1
- PostScript files, printing 1-3
- power
 - cable 2-5 to 2-6, 3-1
 - connector 3-1, 4-5
 - Off 3-18, 4-3
 - precautions 2-3
 - switch 3-1
- power supply
 - cables 4-9
 - description 4-40
 - problems 5-12
 - removal 4-42
 - replacement 4-42
 - voltages 3-2, 4-40
- PPD
 - overview 1-4
- precautions *xiii*
- printing
 - Color Charts 3-16
 - color server test page 3-6
 - Configuration page 3-16
 - Control Panel Map 3-16
 - copier test page 2-3
 - Job Log 3-16
 - options 1-3
 - pages 3-16
 - problems 5-21
- Print Pages option 3-16
- Print screen 3-13 to 3-14

Index

R

- reassembling the system 4-11 to 4-12
- reseating connections 4-8
- reset button 2-7
- restarting 3-18
- restore backup 4-56
- Resume Printing option 3-16
- RIP screen 3-13 to 3-14
- RJ-45 connector 3-10
- Run Diagnostics option 3-17

S

- safety approvals A-1
- scanning 1-1
- screens
 - Alert 3-13 to 3-14
 - Functions 3-7 to 3-8, 3-13, 3-15 to 3-16, 5-18
 - Idle 3-3
 - Info 3-13, 3-15
 - Print 3-13 to 3-14
 - RIP 3-13 to 3-14
- screw locations on back panel 4-4
- SCSI cable 4-9
- serial number 2-5
- serial ports 4-5
- service calls
 - checklist 2-3
 - service kit 2-5
 - tools required *xv*
- service kit 2-5
- service menu 4-56
- service procedures, overview 4-1
- Setup 3-10
- Shut Down option 3-17
- shutting down 3-18, 4-3
- side panel
 - reassembly 4-11
 - removing 4-4
 - screws 4-4, 4-11
- slot assignments 3-5, 4-5, 4-24
- slots
 - copier interface board 4-5
- snap top standoffs 4-27 to 4-28

software

- media package 2-5 to 2-6
- system 4-1, 4-55
- user 2-4, A-1

specifications A-1

startup

- for installation 3-1

startup diagnostics

- beep codes 5-10
- error numbers 5-11
- tests 5-11

Suspend Printing option 3-16

switch 3-1, 4-36

system errors 5-12

system software 4-1, 4-55

T

- TCP/IP 1-1
- terminology *xii*
- Test I/F Board Diagnostics option 3-17
- Test Page
 - copier 2-3
 - printing from the Function menu 3-6
- Token Ring 2-3, 3-9
- tools required for service/installation *xv*
- troubleshooting
 - beep codes 5-10
 - buttons 5-12
 - Control Panel 5-12
 - DIMMs 5-10
 - fan 5-12
 - motherboard 5-10
 - power supply 5-12
 - printing problems 5-21
 - process 5-1
 - system error conditions 5-12
- twisted pair (10BaseT/100BaseT) 2-3, 3-9 to 3-10

U

- UIB
 - cable 4-9, 4-20 to 4-21
 - enclosure 4-21 to 4-22
- unpacking 2-5

Index

up button 2-7, 3-11 to 3-12, 4-20
user interface board
 accessing 4-6
 activity light 4-20, 5-9
 connector 4-20
 description 4-20
 display window 4-20
 line selection buttons (move left/right
 buttons) 4-20
 menu button 4-20
 removal 4-21
 replacement 4-22
 UIB cable 4-21
 UIB enclosure 4-21 to 4-22
 up/down buttons 4-20

user software 2-4, A-1
User Software CD
 Adobe PS Printer Driver 1-4
UTP (unshielded twisted pair) 3-10

V

voltage A-2
 checking 3-2, 4-40

W

WebTools 1-4 to 1-5

Z

ZIP drive 4-48 to 4-49